

US 20240369434A1

(19) **United States**

(12) **Patent Application Publication**  
**JORDAN et al.**

(10) **Pub. No.: US 2024/0369434 A1**

(43) **Pub. Date: Nov. 7, 2024**

(54) **BICYCLE WHEEL WITH AN INTEGRATED SENSOR DEVICE**

*B60B 21/10* (2006.01)

*B60C 23/04* (2006.01)

*G01L 19/14* (2006.01)

(71) Applicant: **SRAM, LLC**, Chicago, IL (US)

(52) **U.S. Cl.**

CPC ..... *G01L 17/00* (2013.01); *B60B 21/025*

(2013.01); *B60B 21/10* (2013.01); *B60C*

*23/0498* (2013.01); *G01L 19/14* (2013.01)

(72) Inventors: **BRIAN JORDAN**, CHICAGO, IL (US); **DAVID MORSE**, INDIANAPOLIS, IN (US); **SHELBY SESSIONS**, CHICAGO, IL (US); **RUAN TROUW**, MOORESVILLE, IN (US)

(57) **ABSTRACT**

A rim for a bicycle wheel includes a radially inner portion disposed along an inner circumference of the rim, a first sidewall, and a second sidewall spaced apart from the first sidewall. The first sidewall and the second sidewall extend radially outward from the radially inner portion. The rim also includes a radially outer tire engaging portion disposed along an outer circumference of the rim. The radially outer tire engaging portion extends from the first sidewall and the second sidewall, respectively. The rim also includes an opening through the radially inner portion at a first circumferential position along the inner circumference. An air valve of the bicycle wheel is positionable through the opening. The rim also includes a receptacle for a sensor device within the radially inner portion at a second circumferential position along the inner circumference. The second circumferential position is different than the first circumferential position.

(73) Assignee: **SRAM, LLC**, Chicago, IL (US)

(21) Appl. No.: **18/630,456**

(22) Filed: **Apr. 9, 2024**

**Related U.S. Application Data**

(60) Provisional application No. 63/464,220, filed on May 5, 2023.

**Publication Classification**

(51) **Int. Cl.**

*G01L 17/00* (2006.01)

*B60B 21/02* (2006.01)

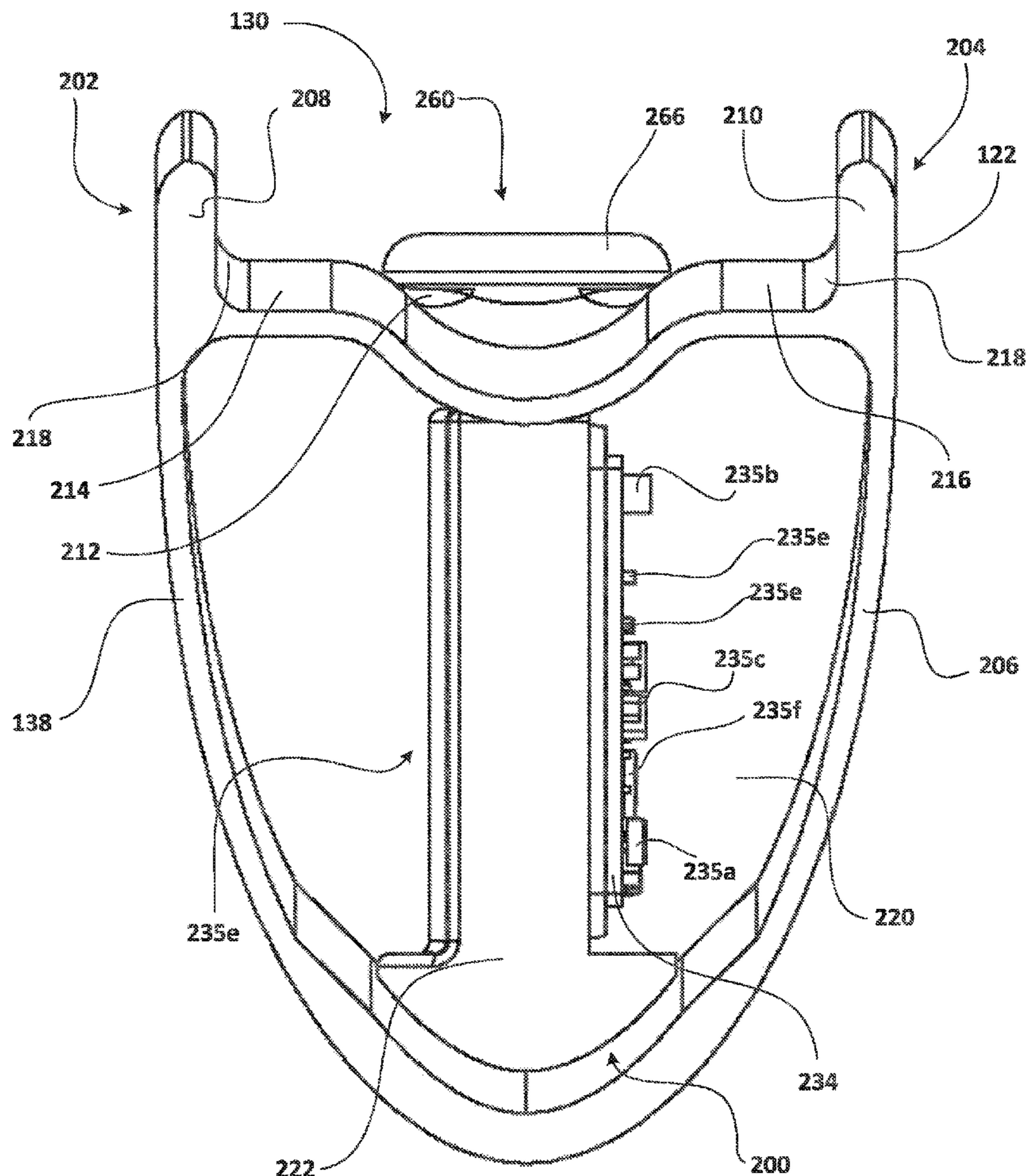

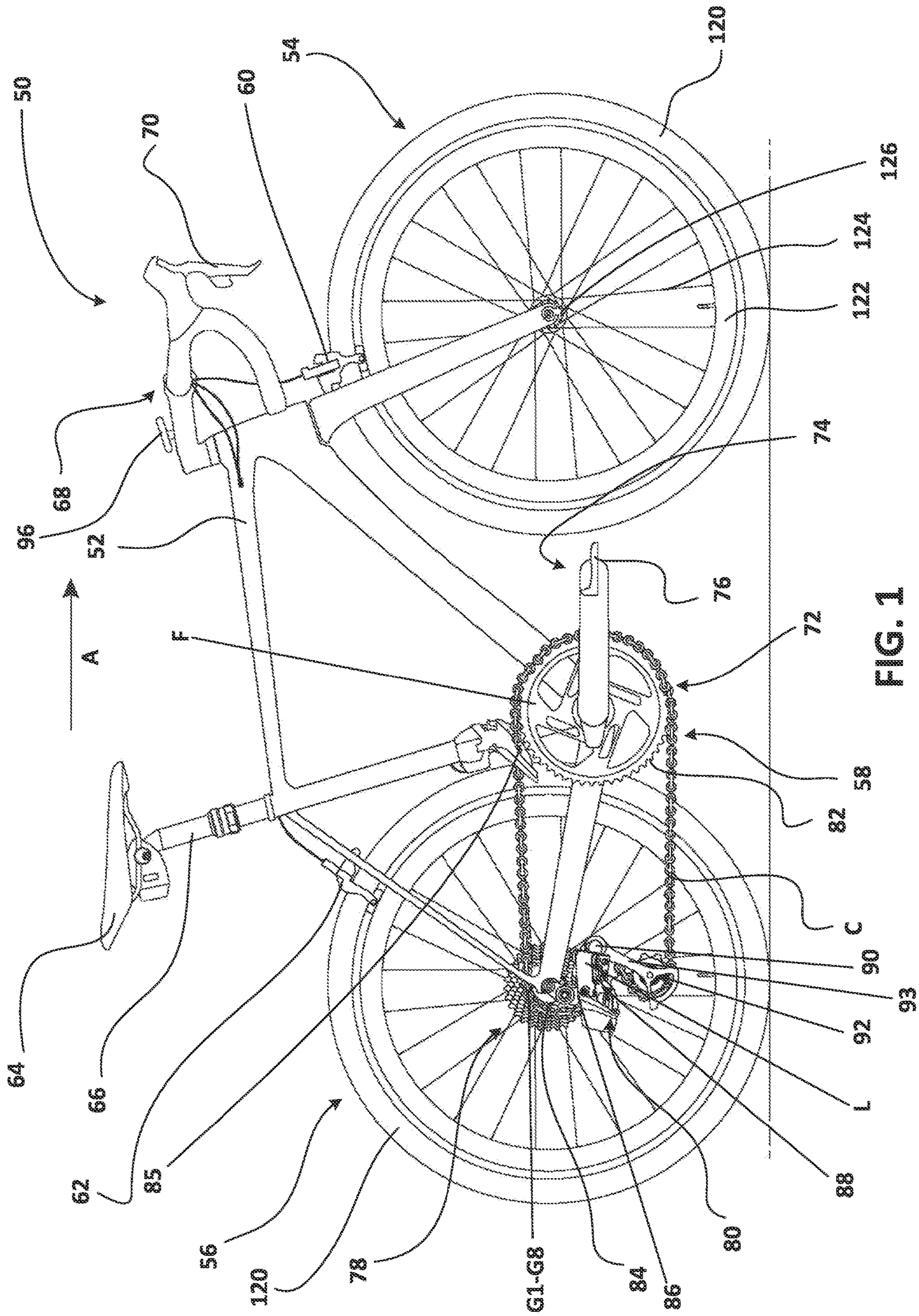

FIG. 1

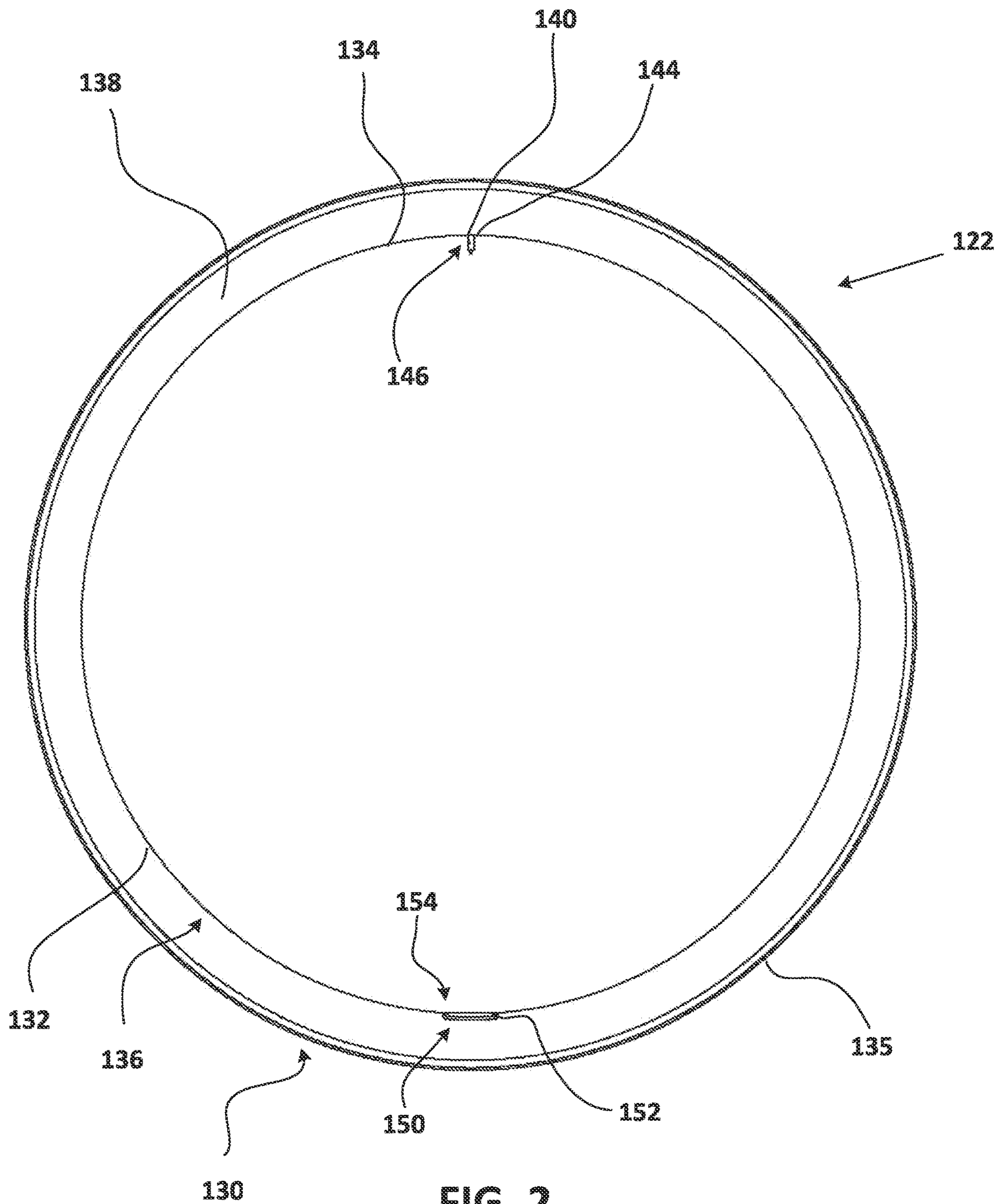

FIG. 2

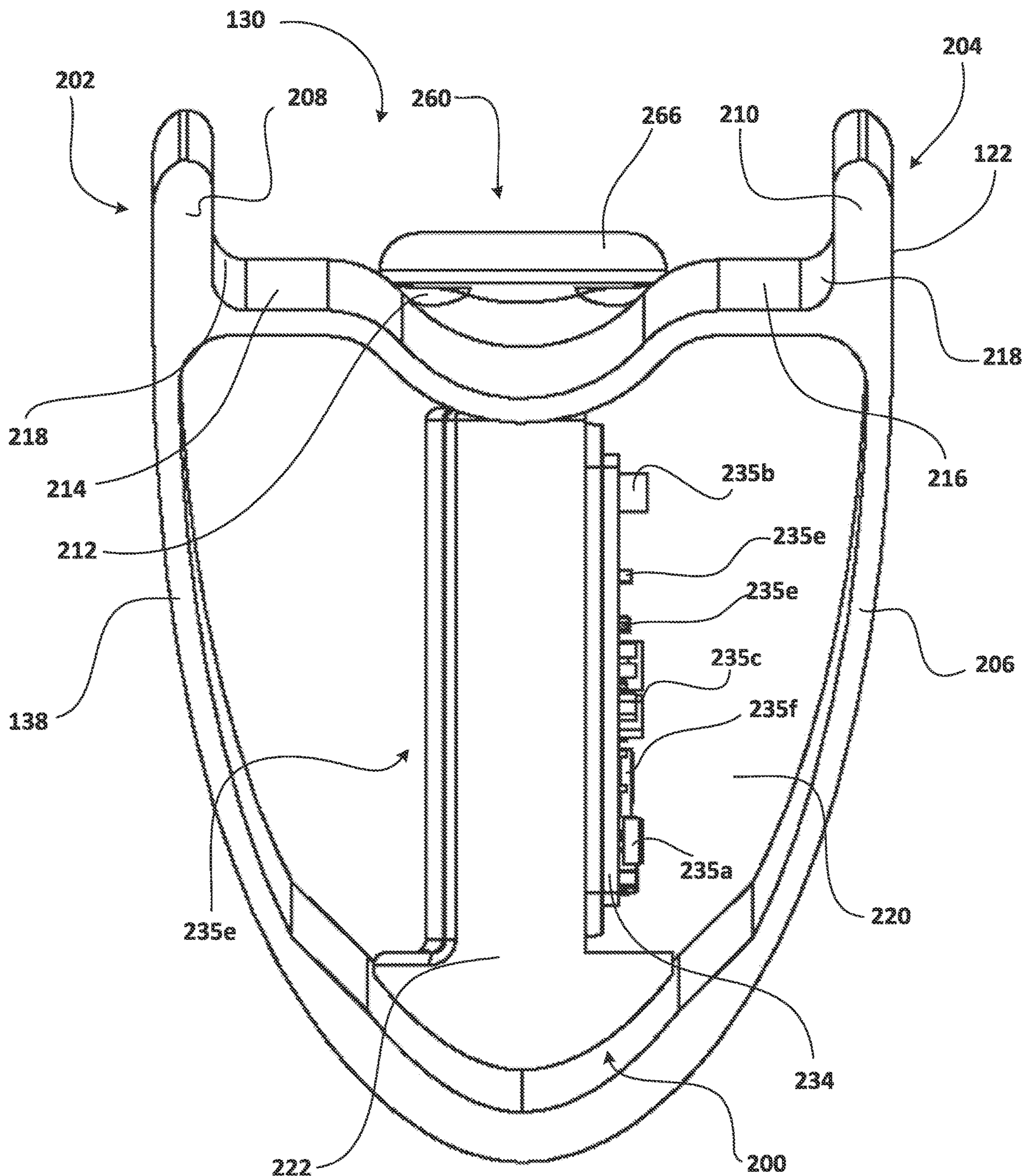

FIG. 3

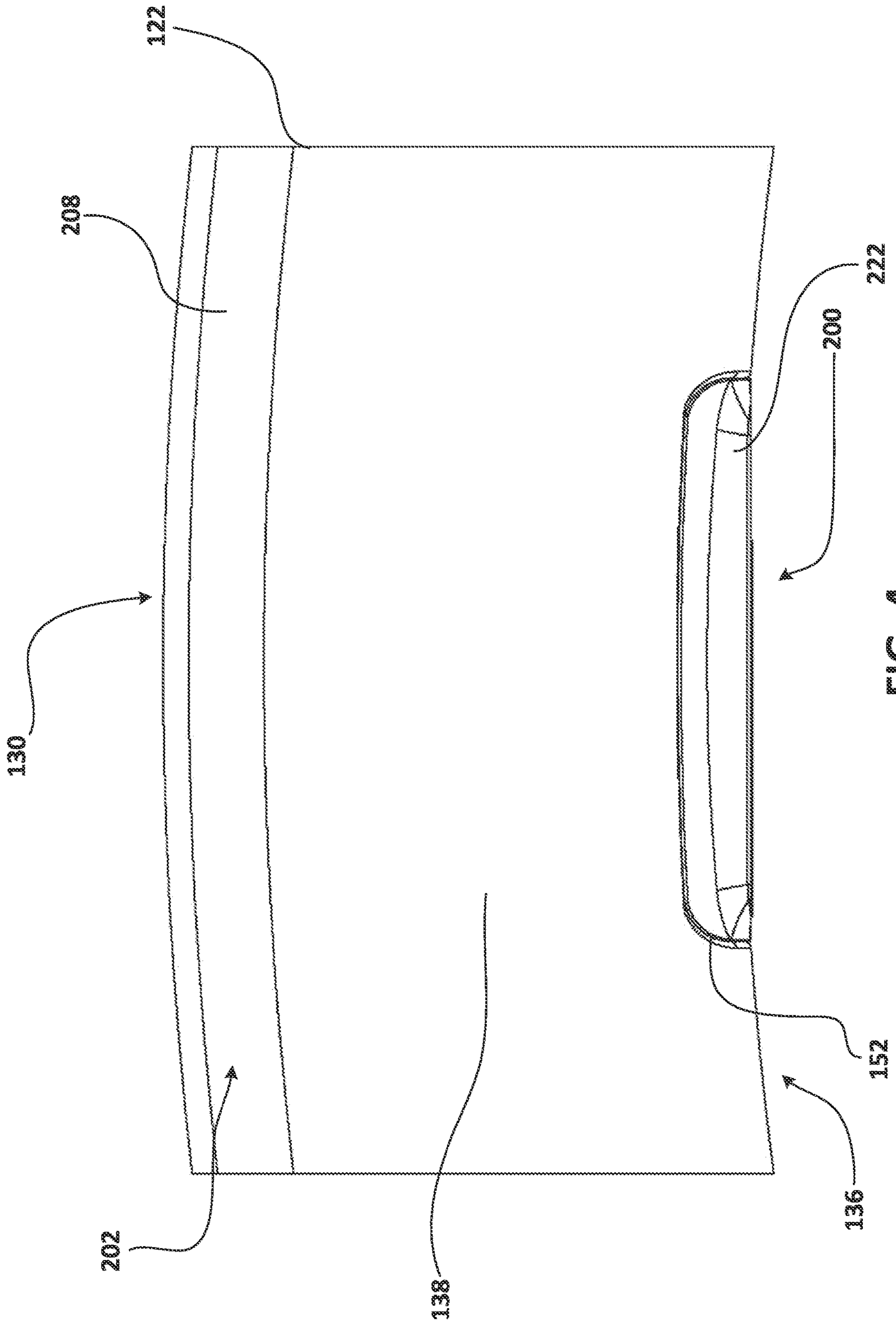

FIG. 4

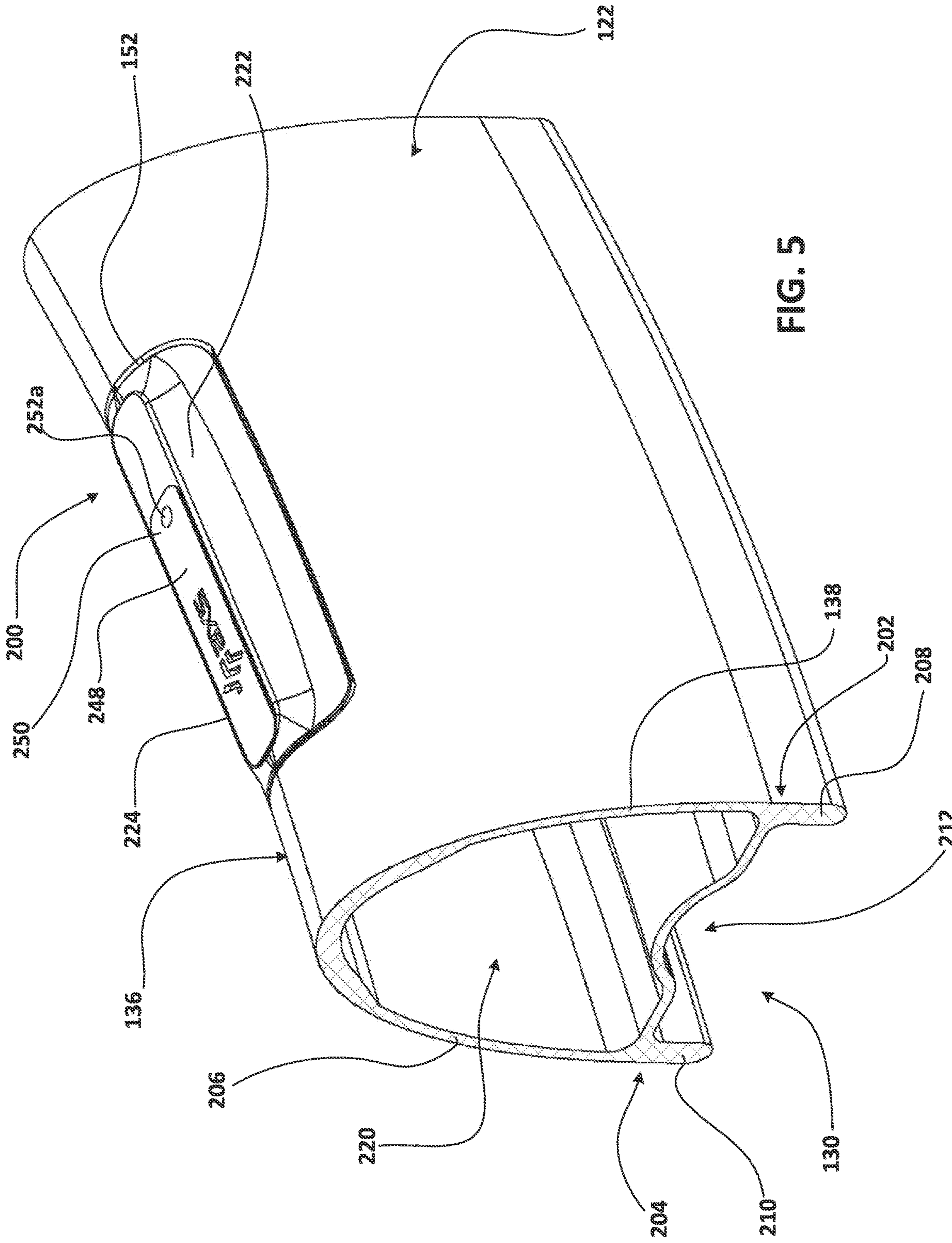
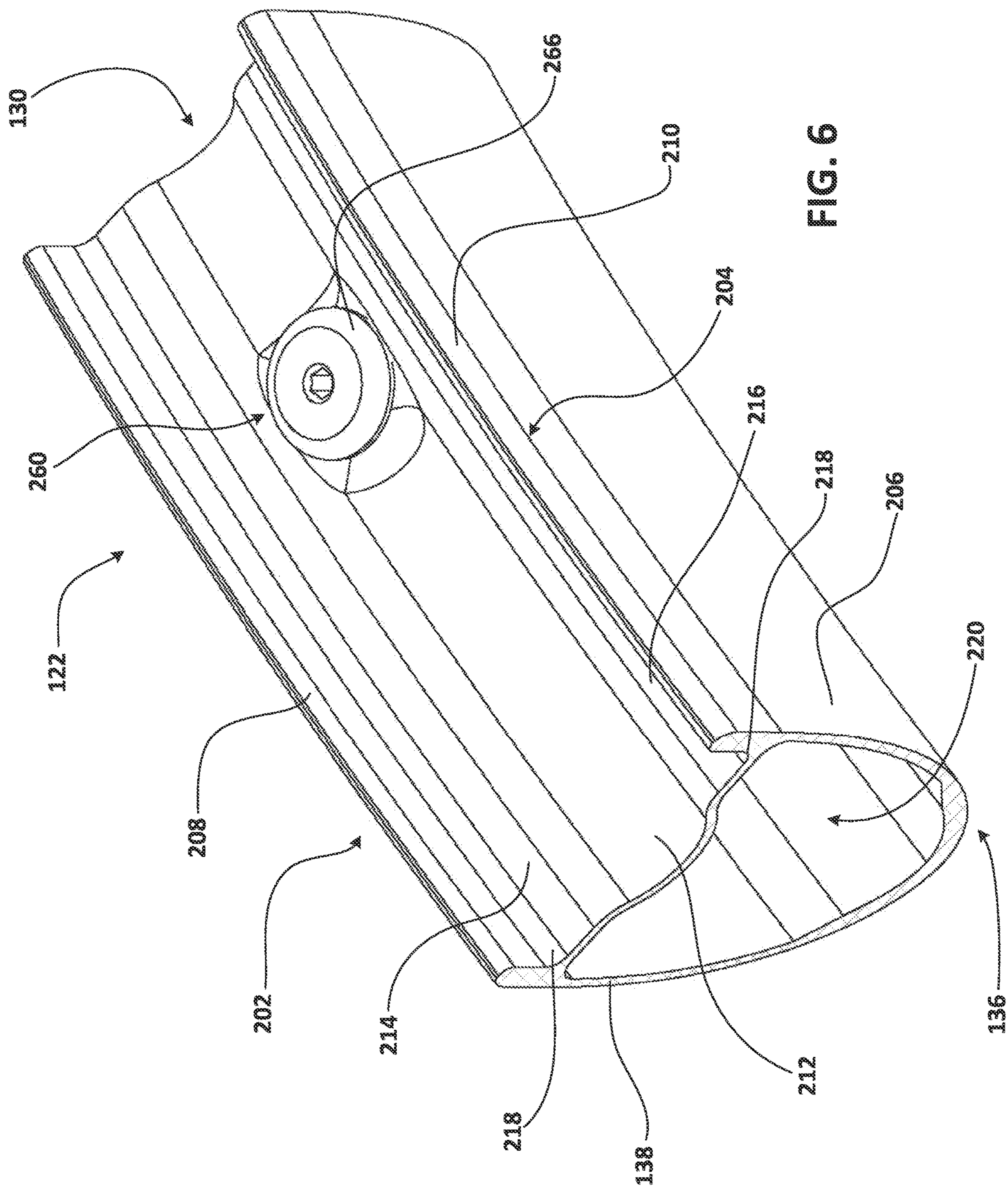

FIG. 5



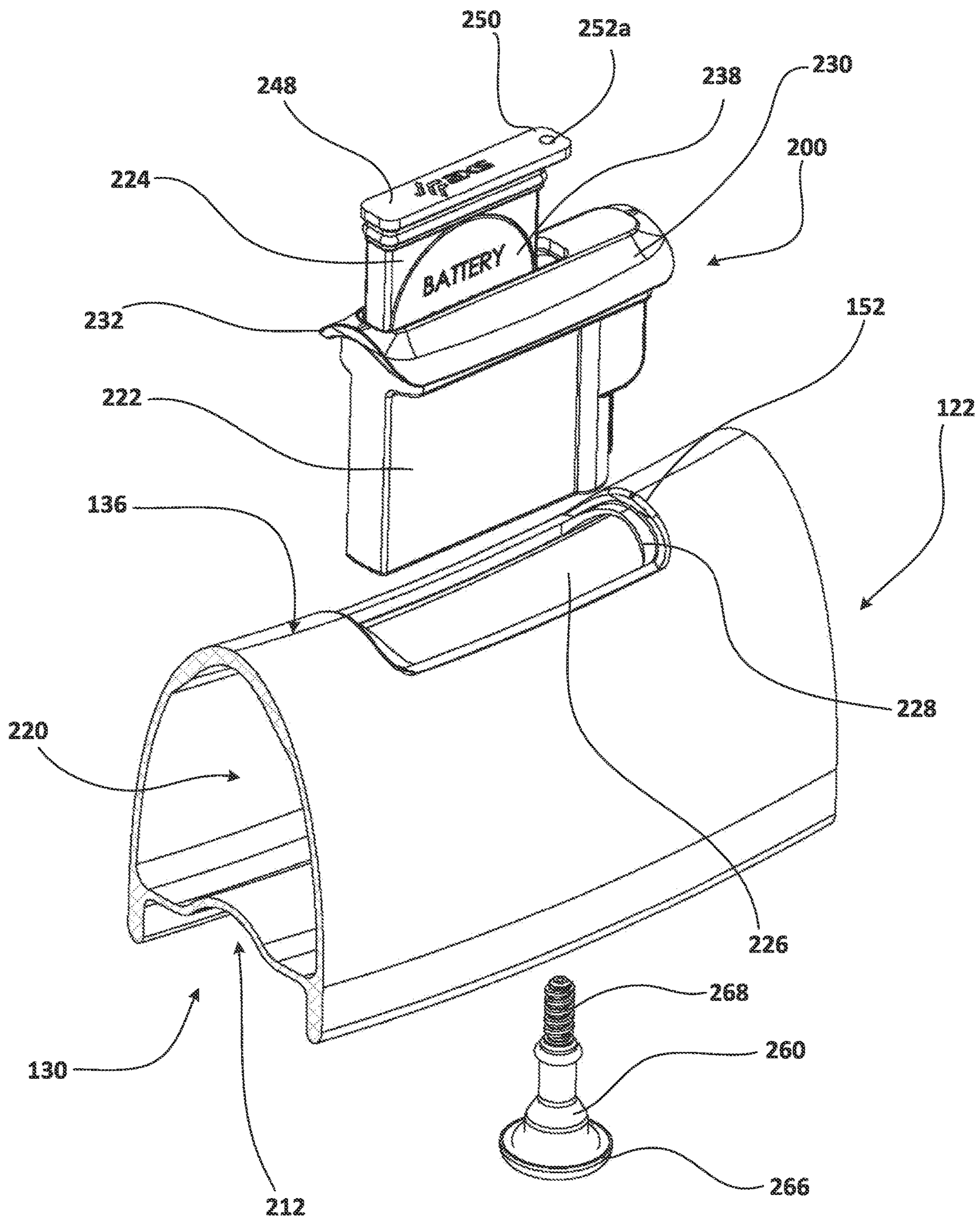

FIG. 7



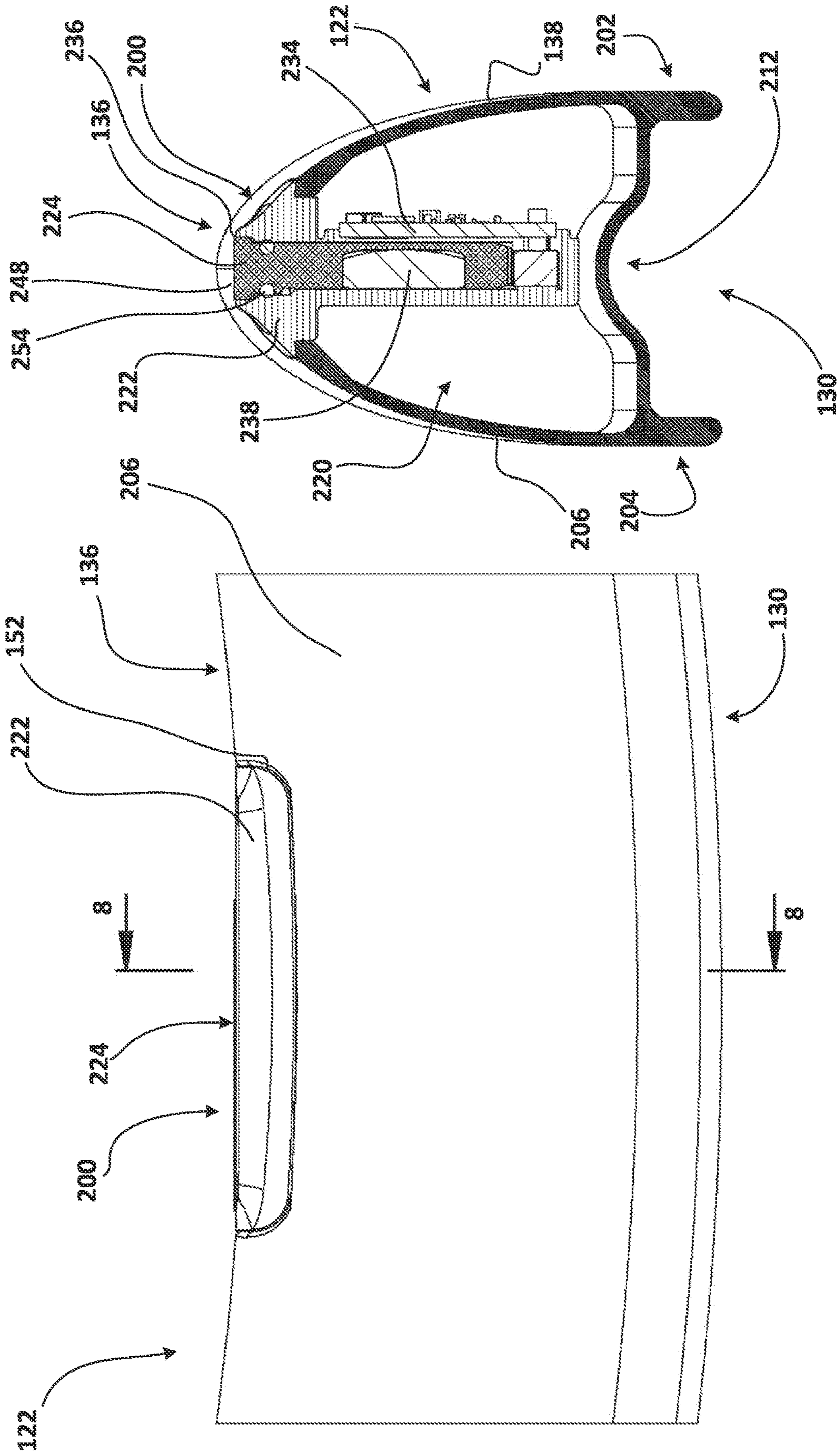
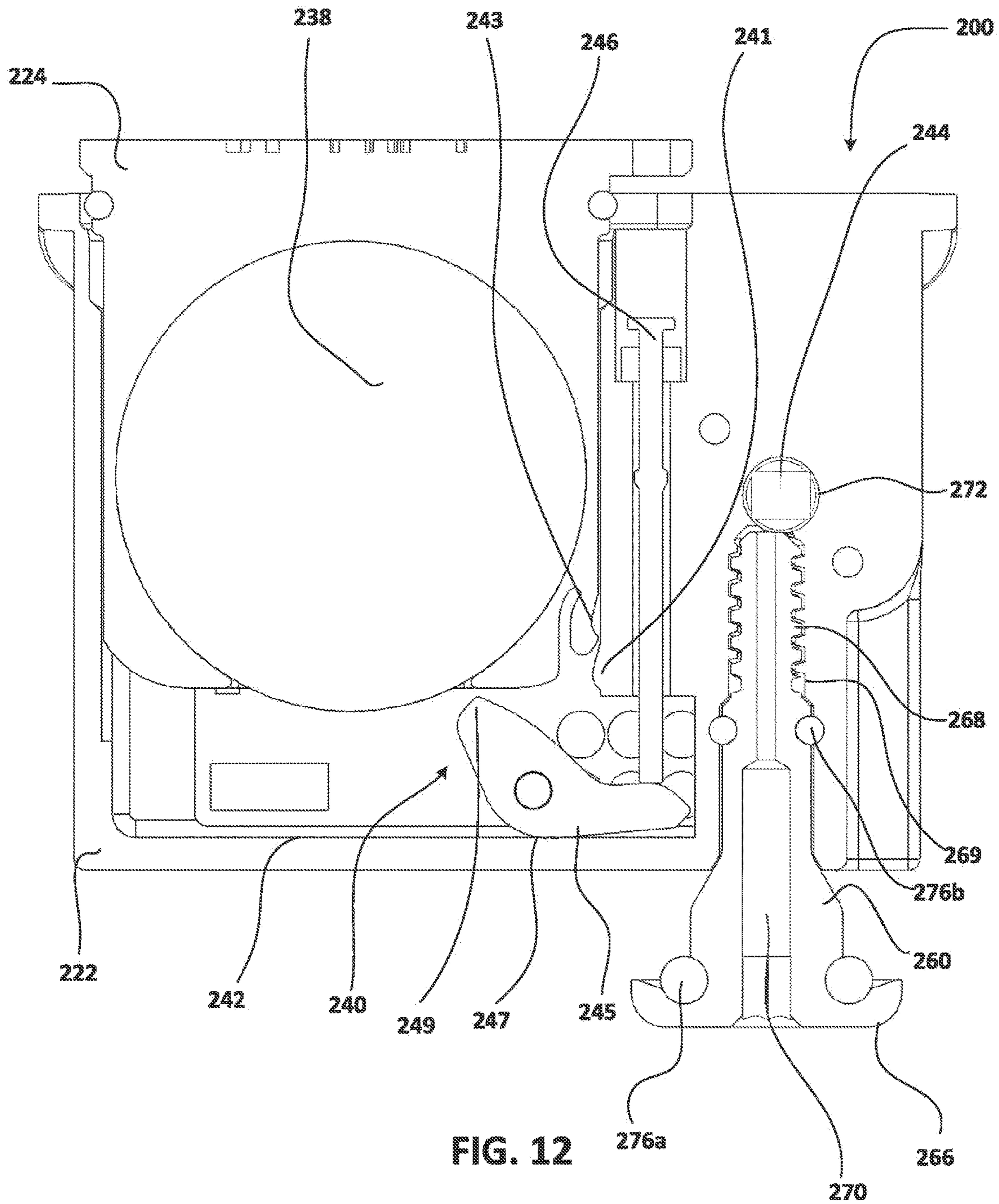

FIG. 8

FIG. 9





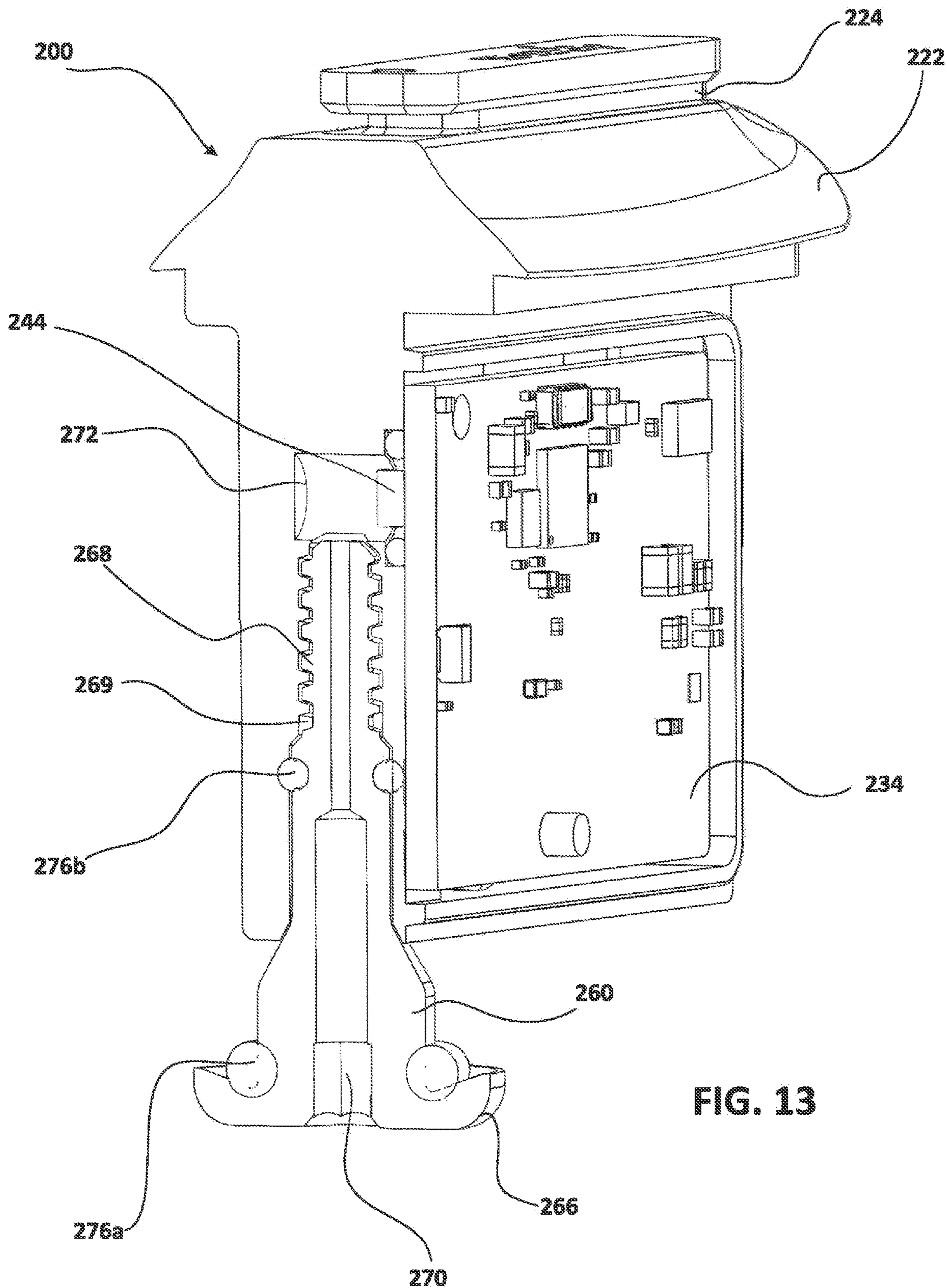
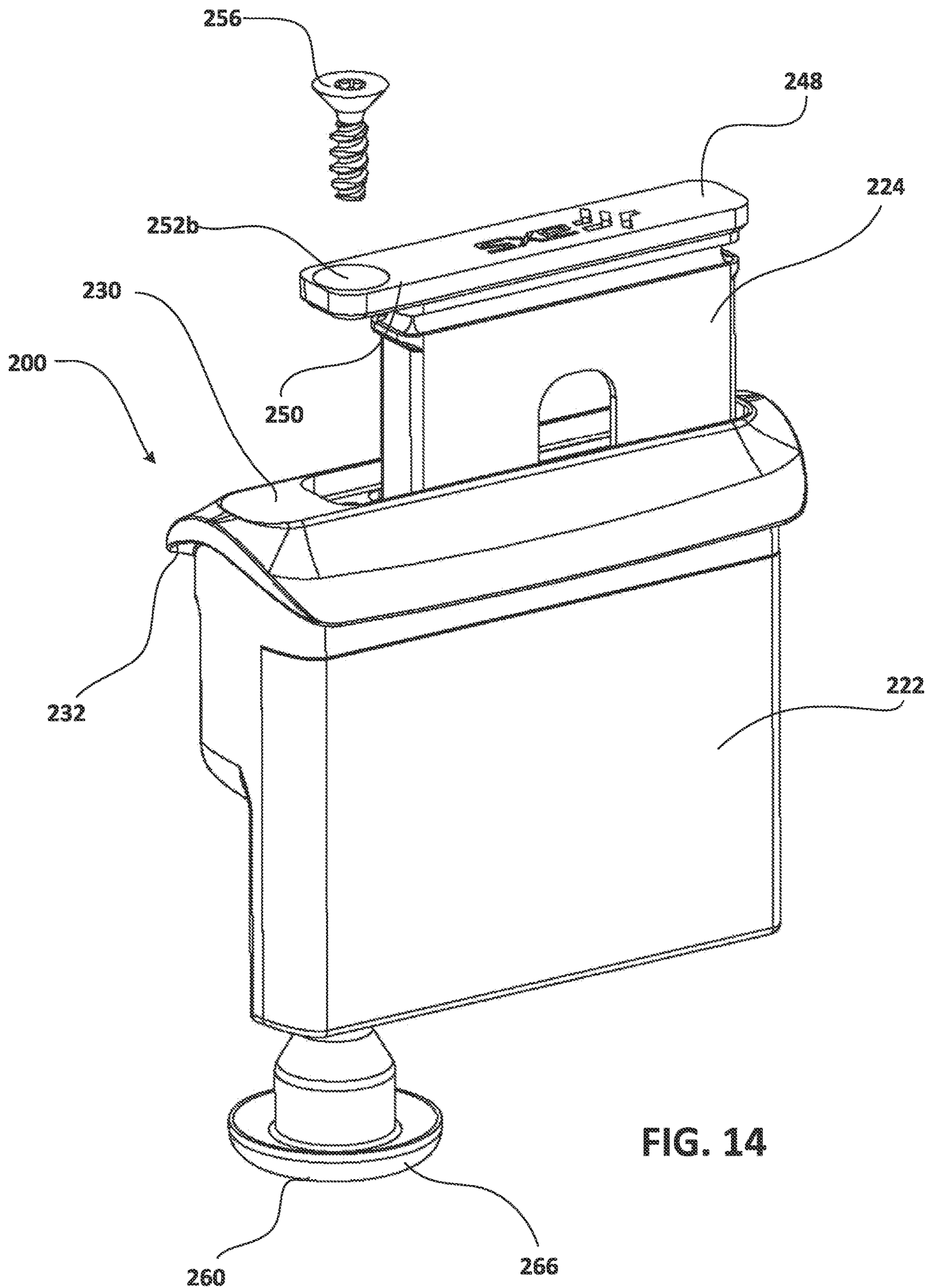

FIG. 13



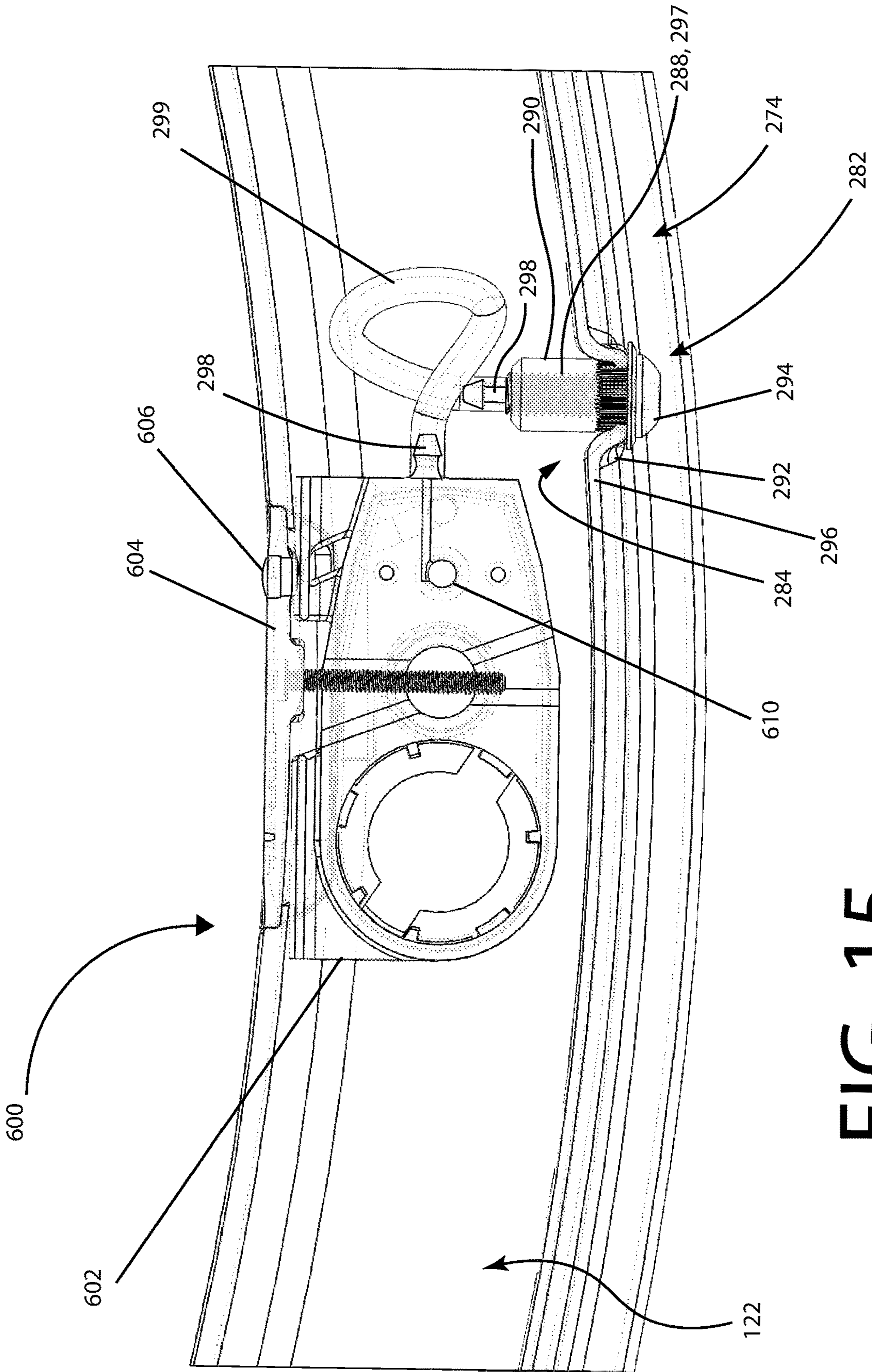

FIG. 15

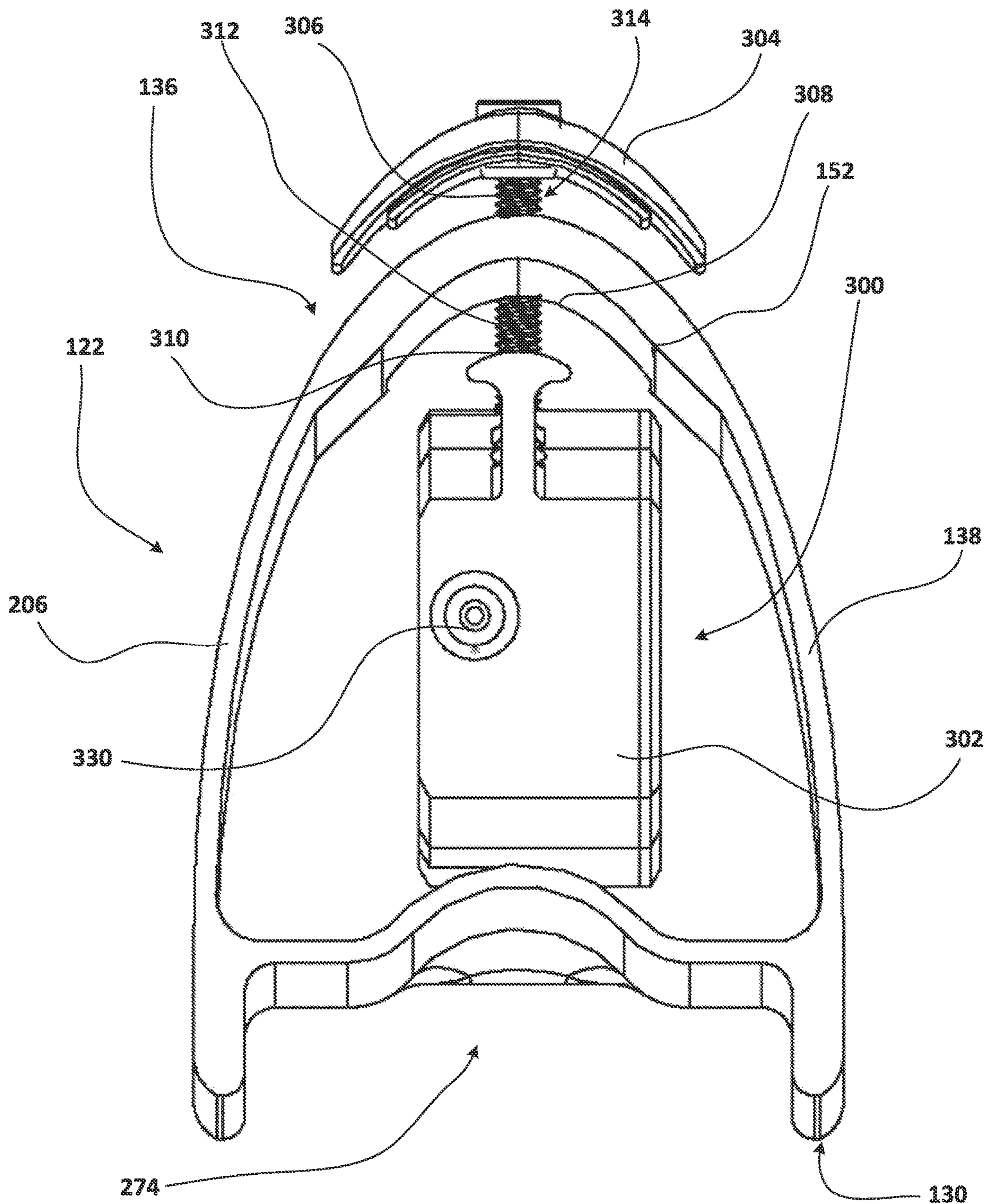

FIG. 16

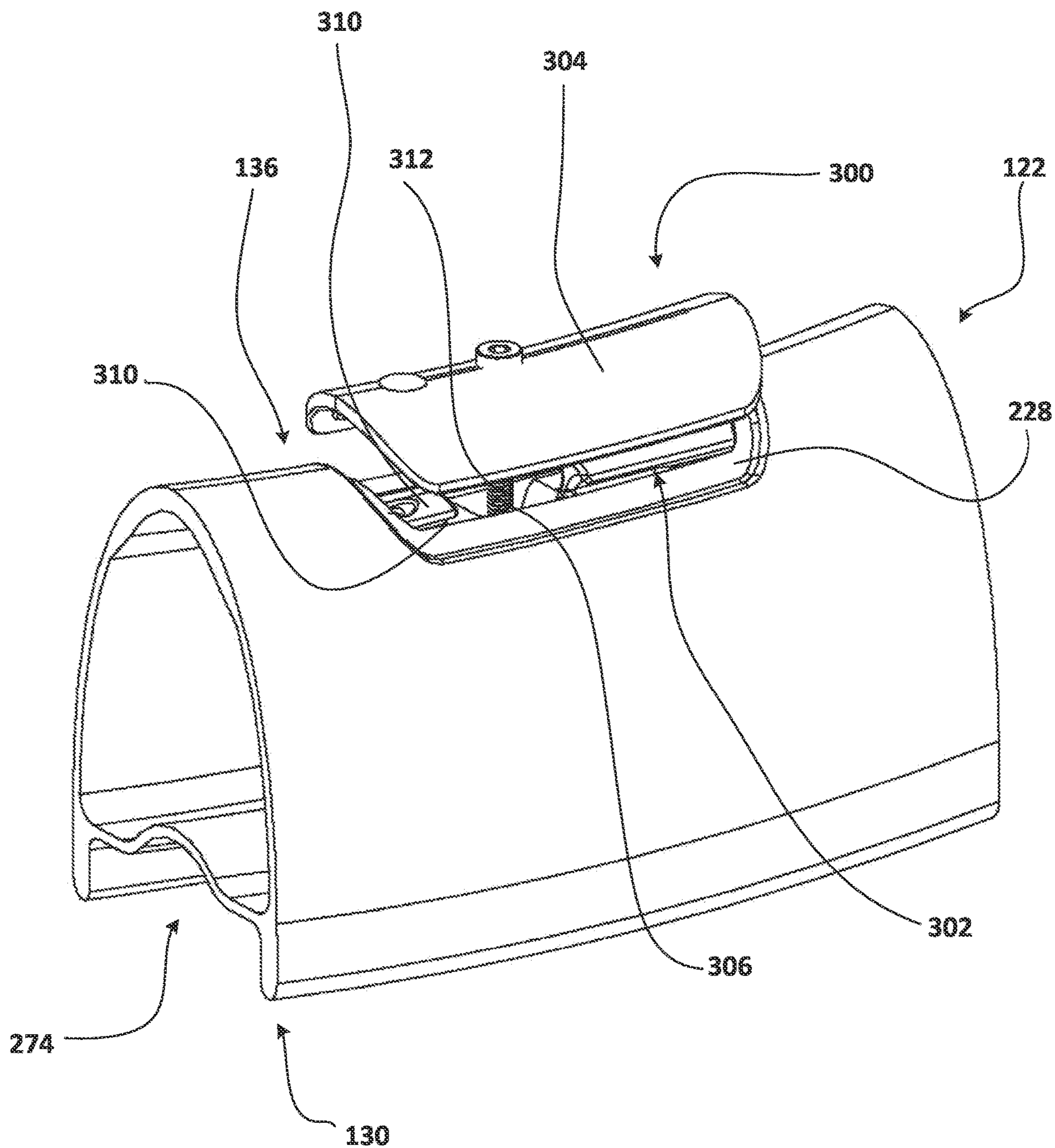

FIG. 17



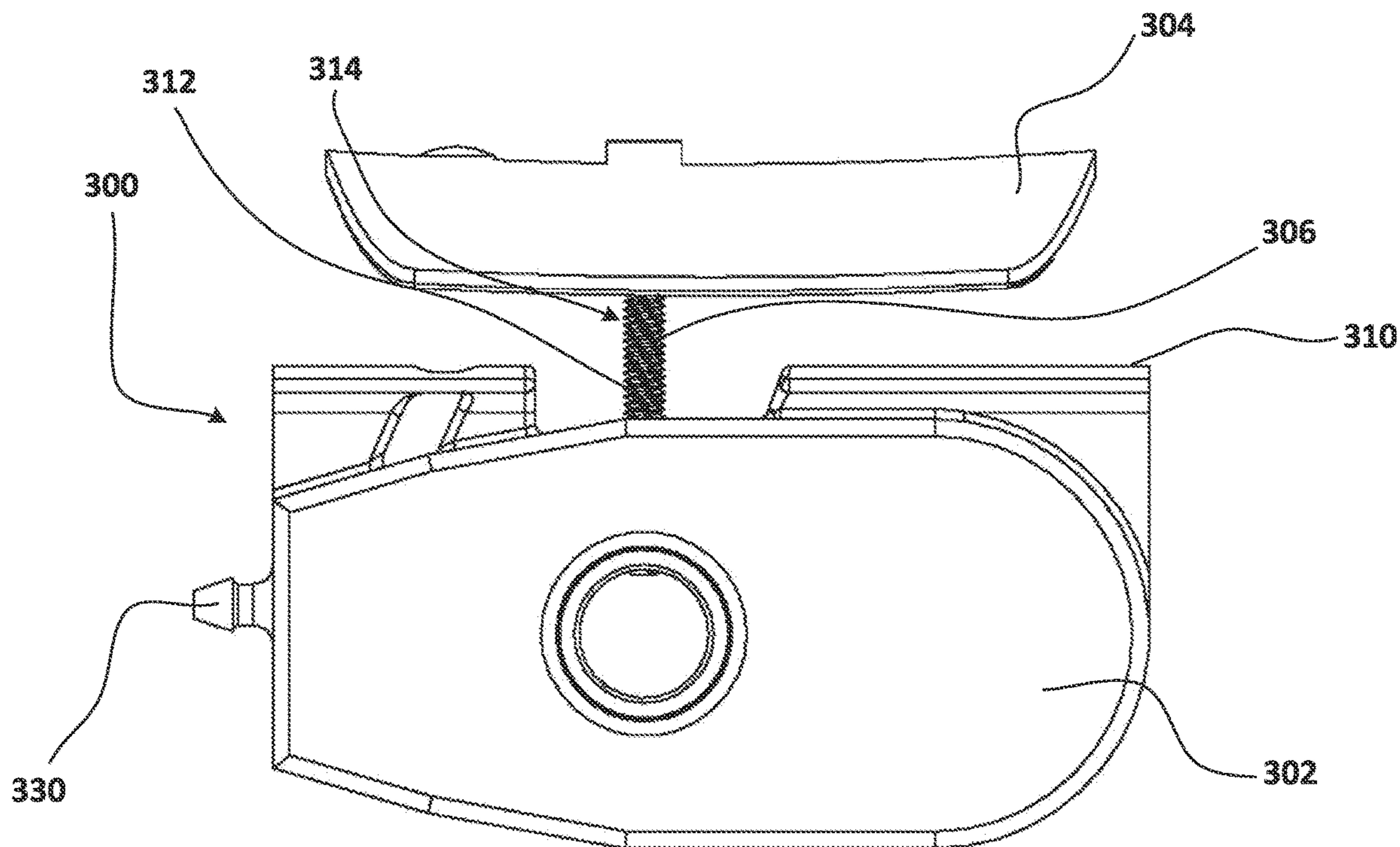

FIG. 18

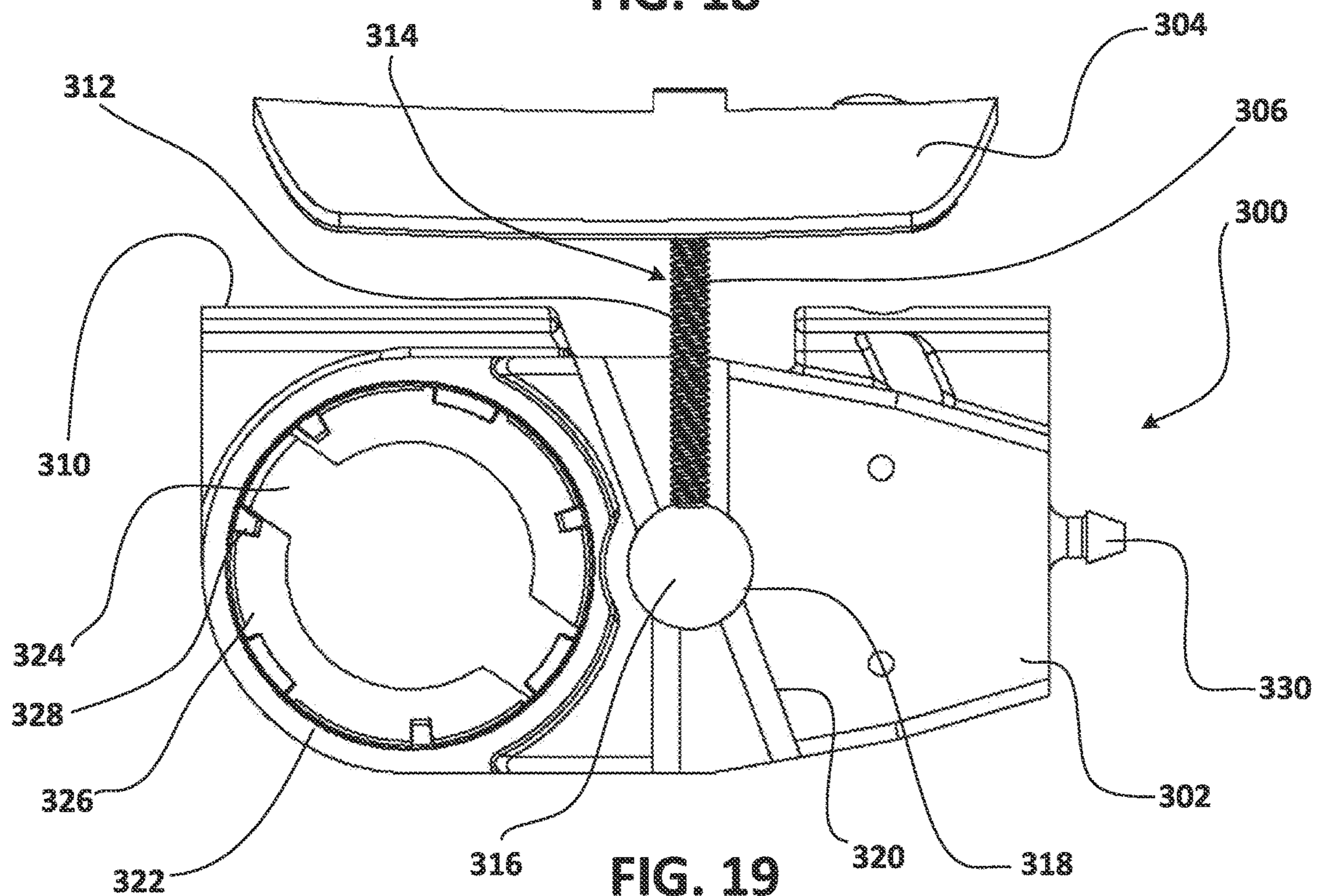

FIG. 19

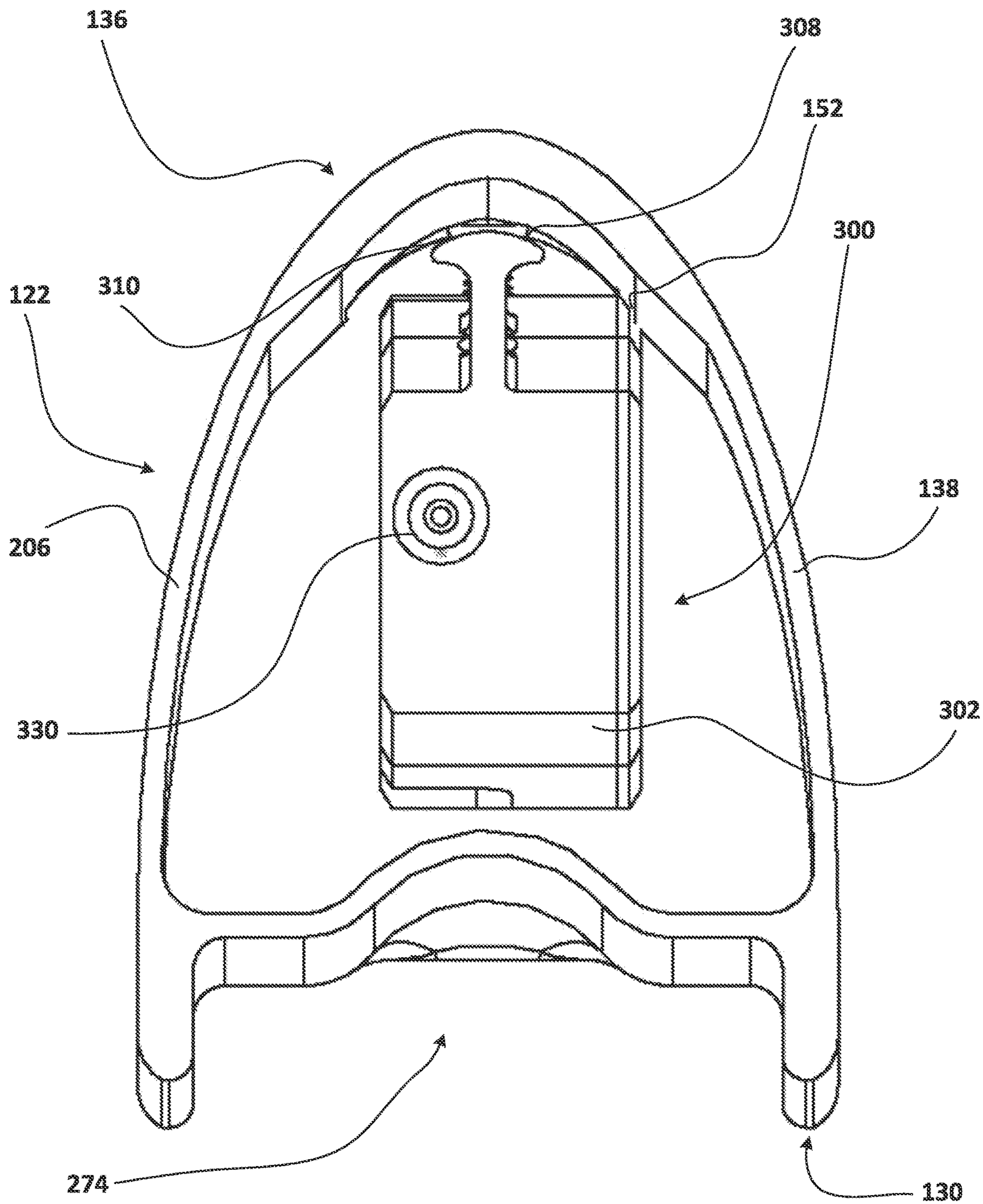

FIG. 20

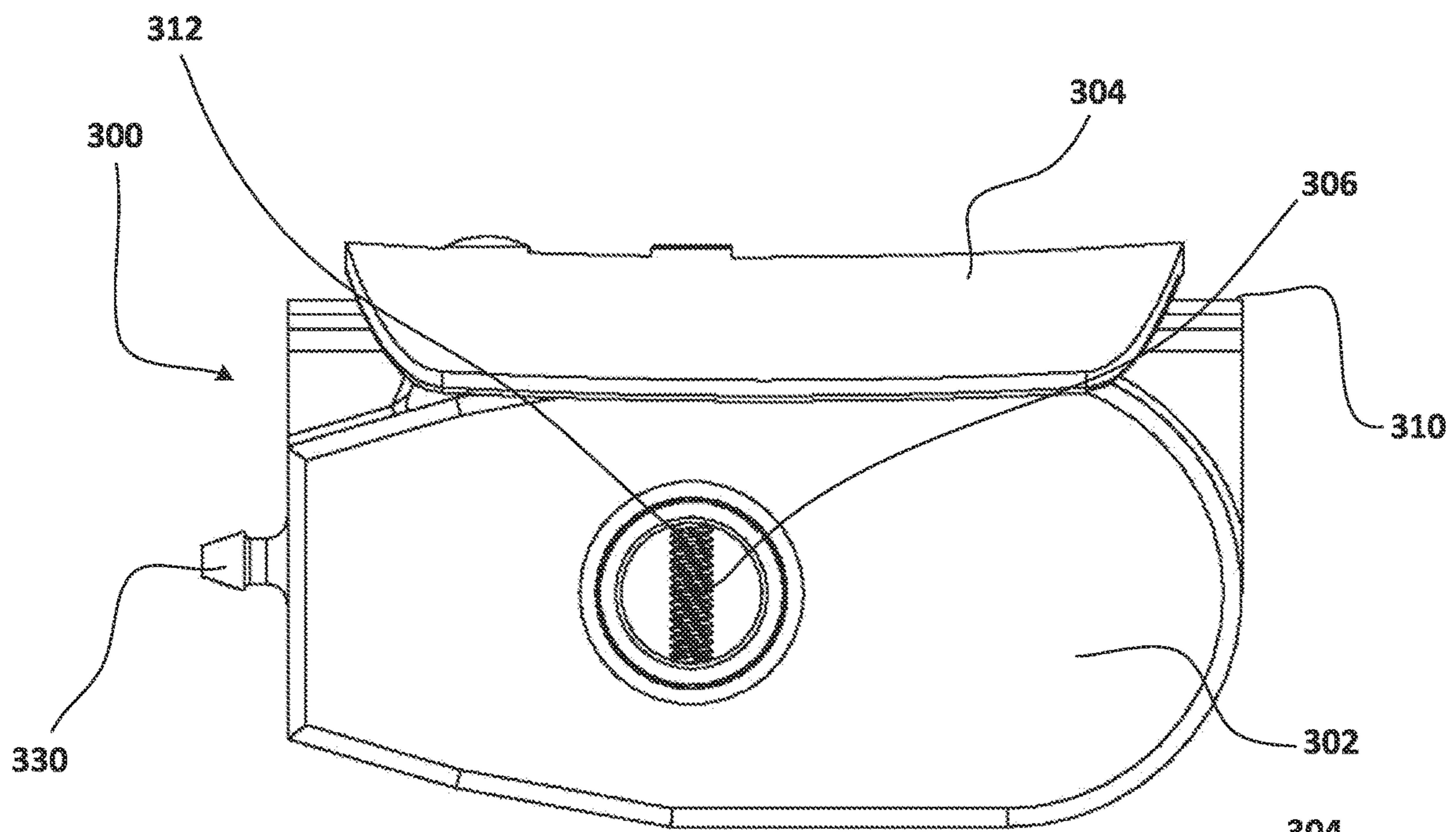

FIG. 21

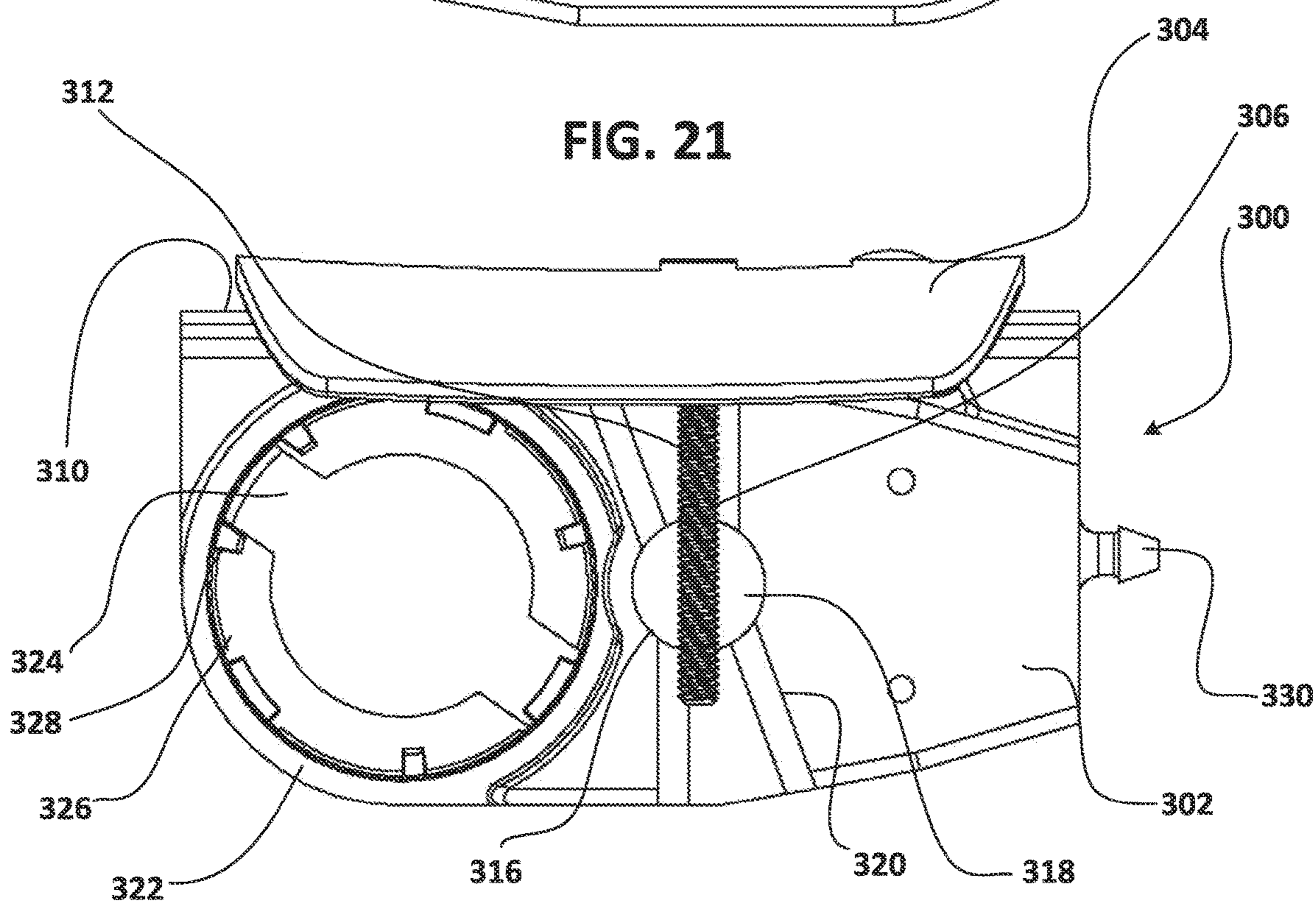

FIG. 22

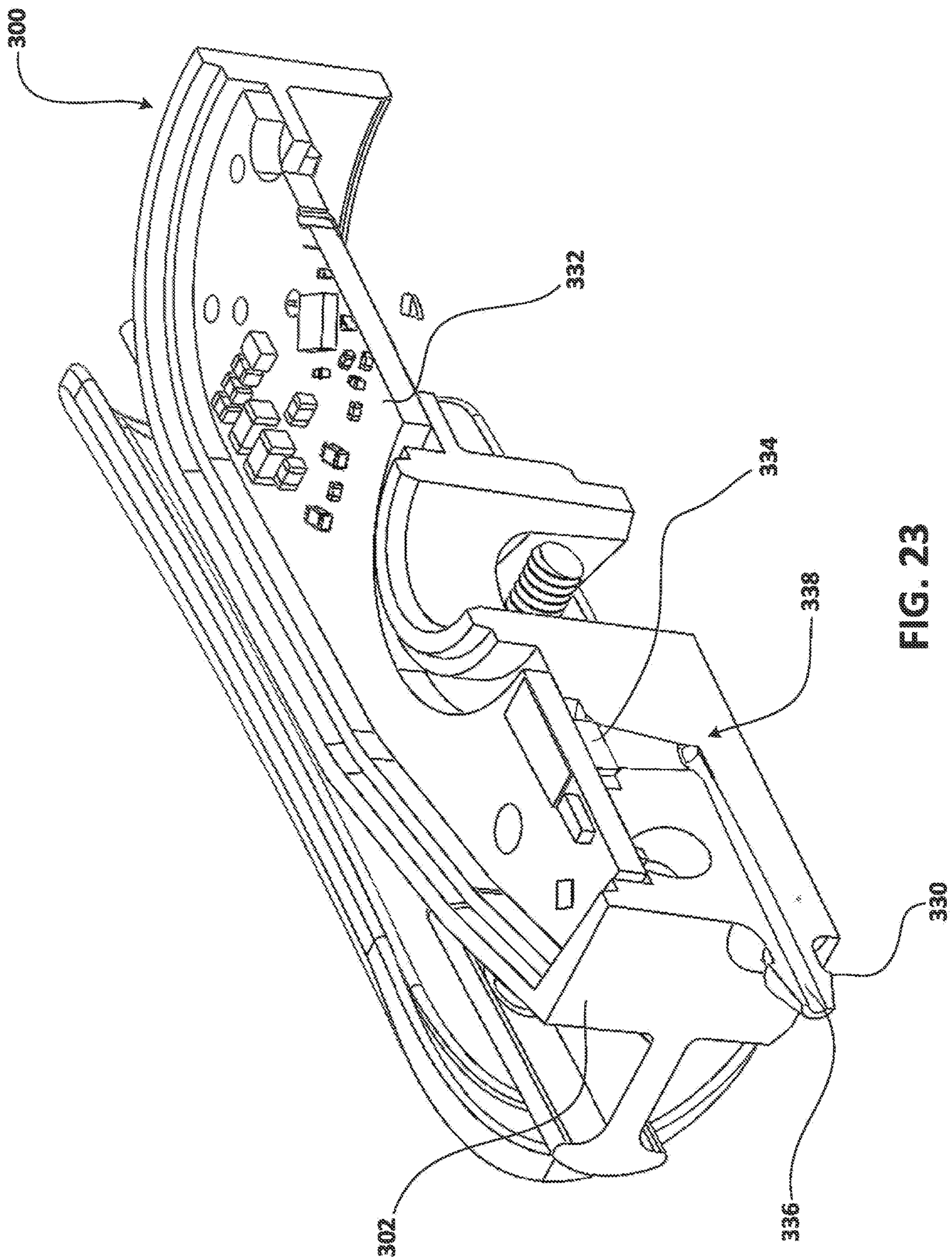

FIG. 23

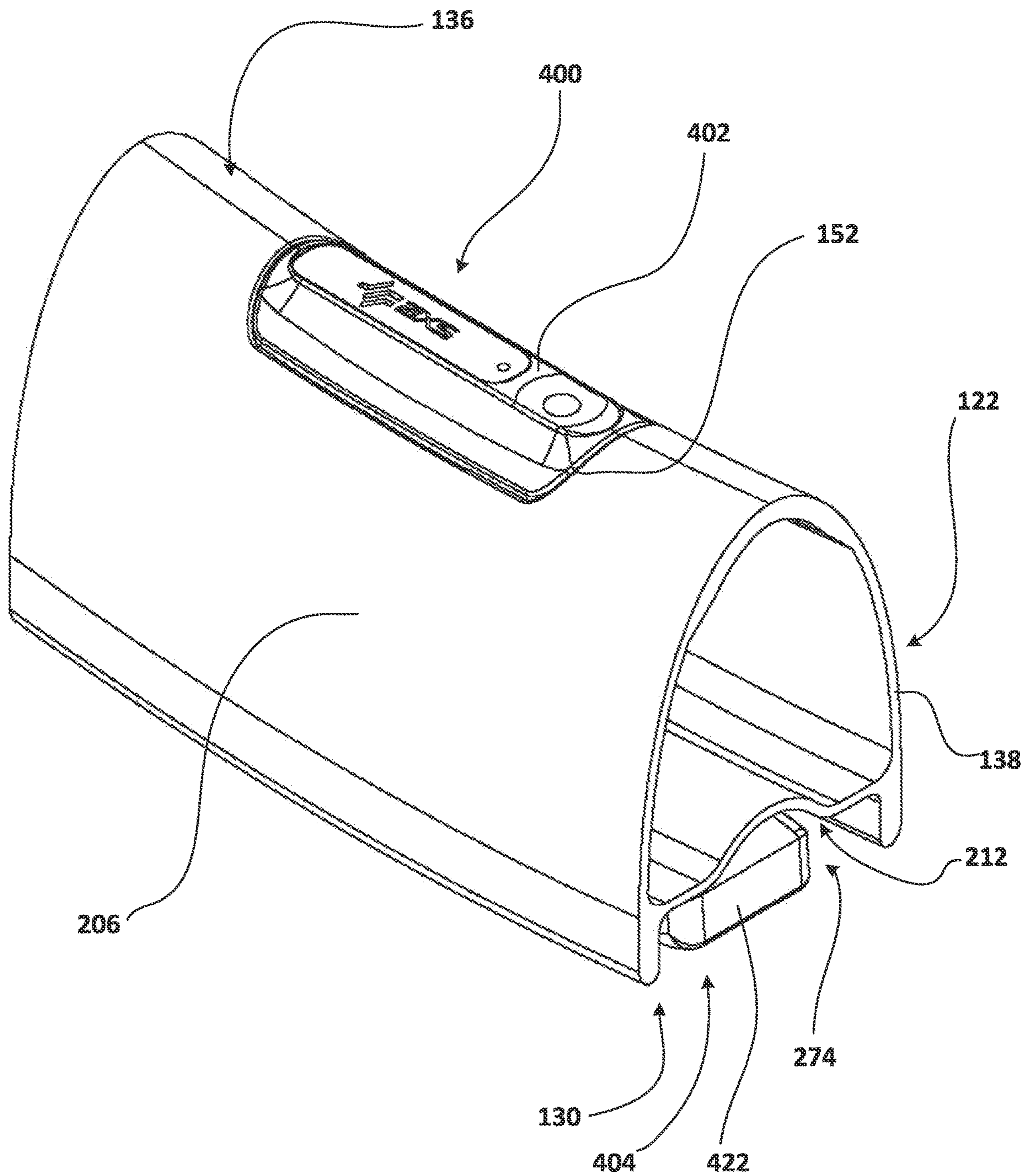

FIG. 24

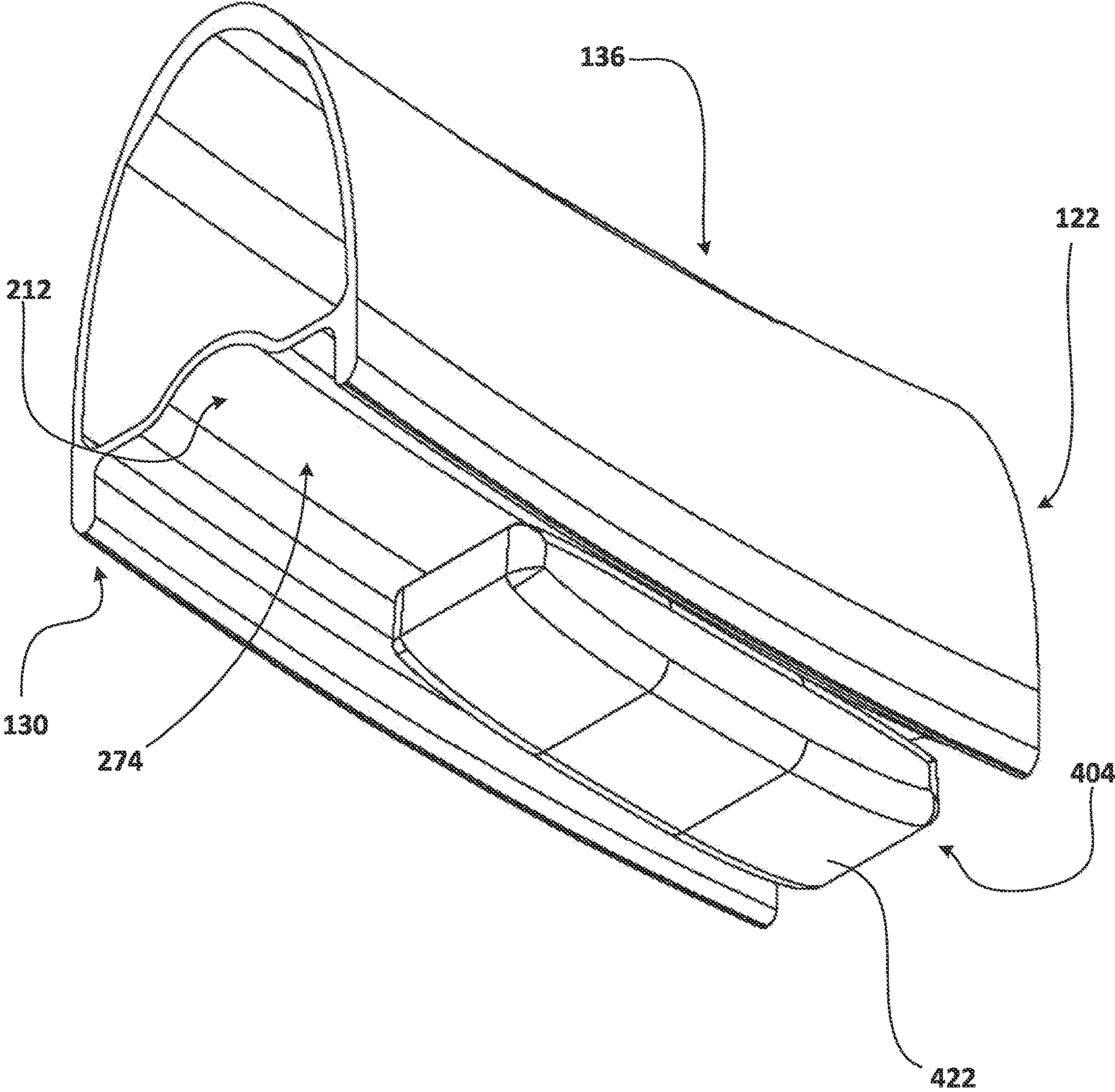

FIG. 25

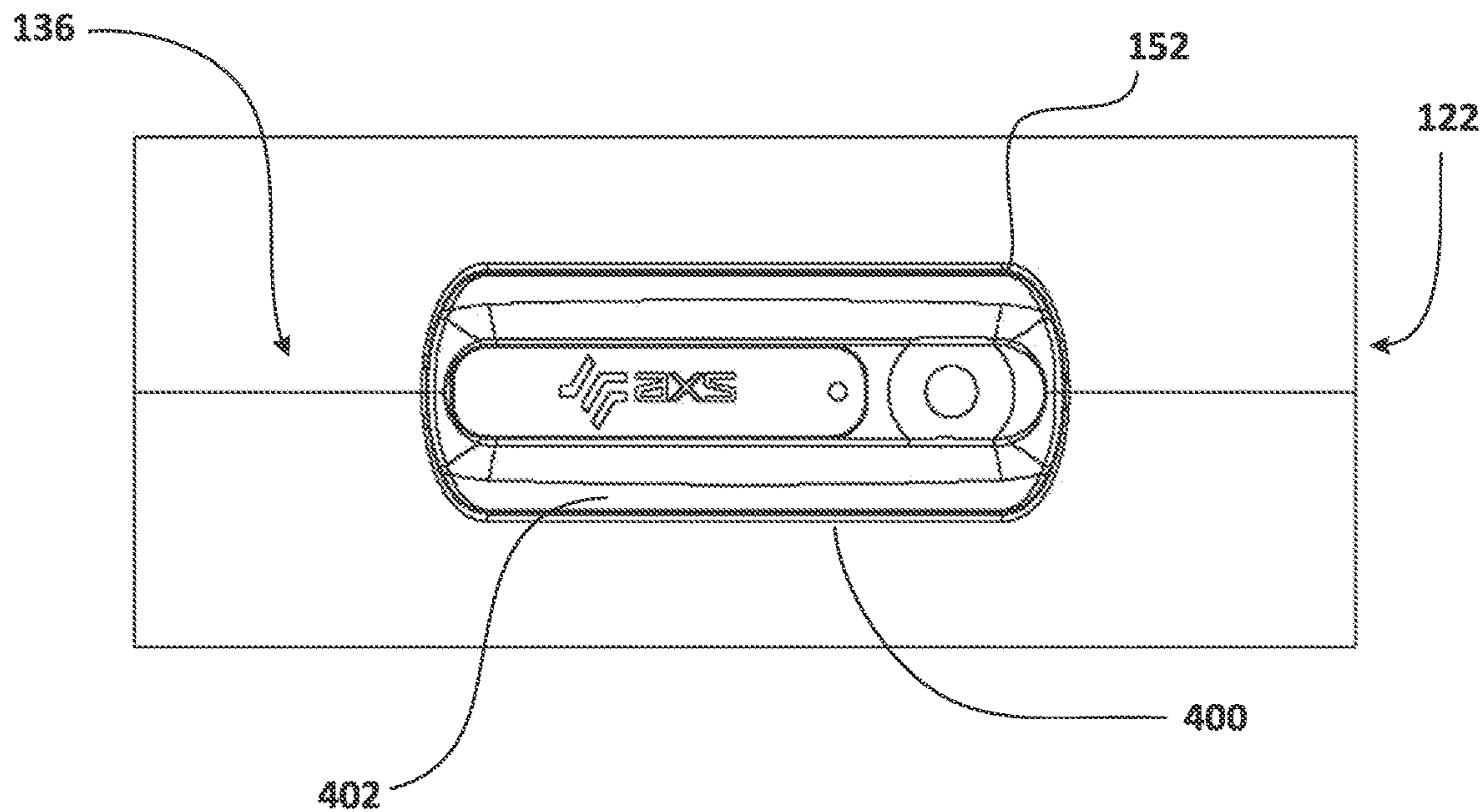

FIG. 26

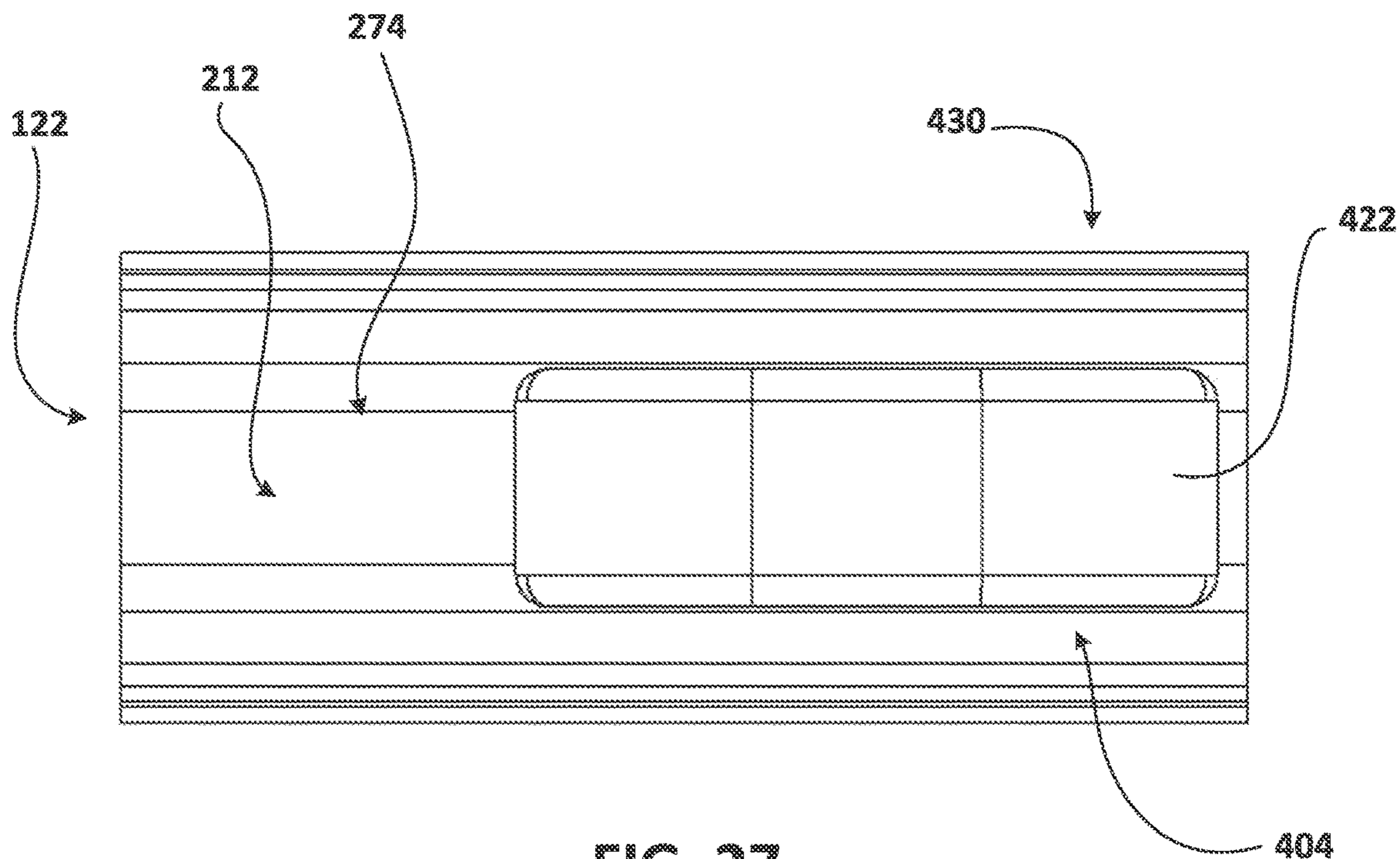

FIG. 27

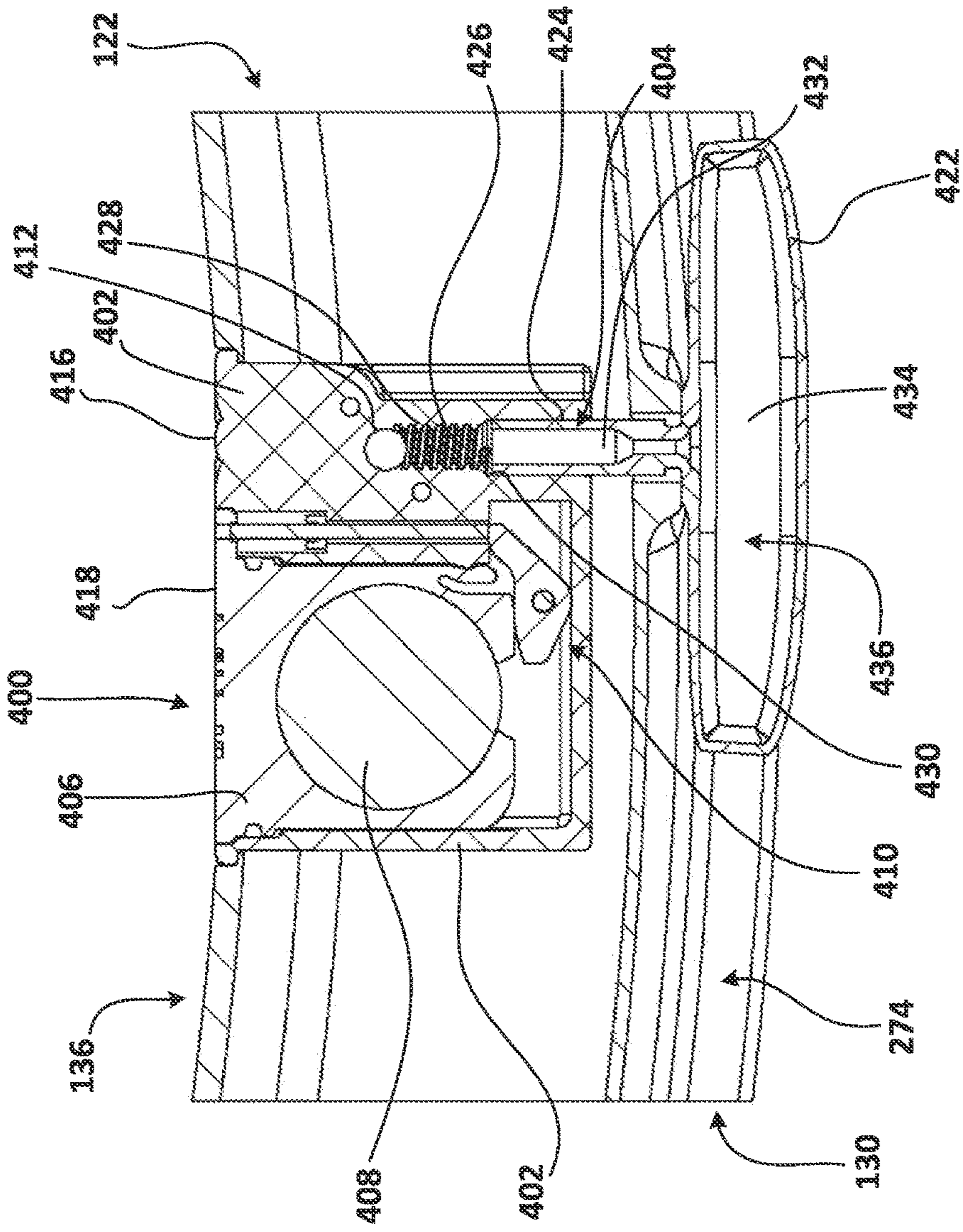

FIG. 28

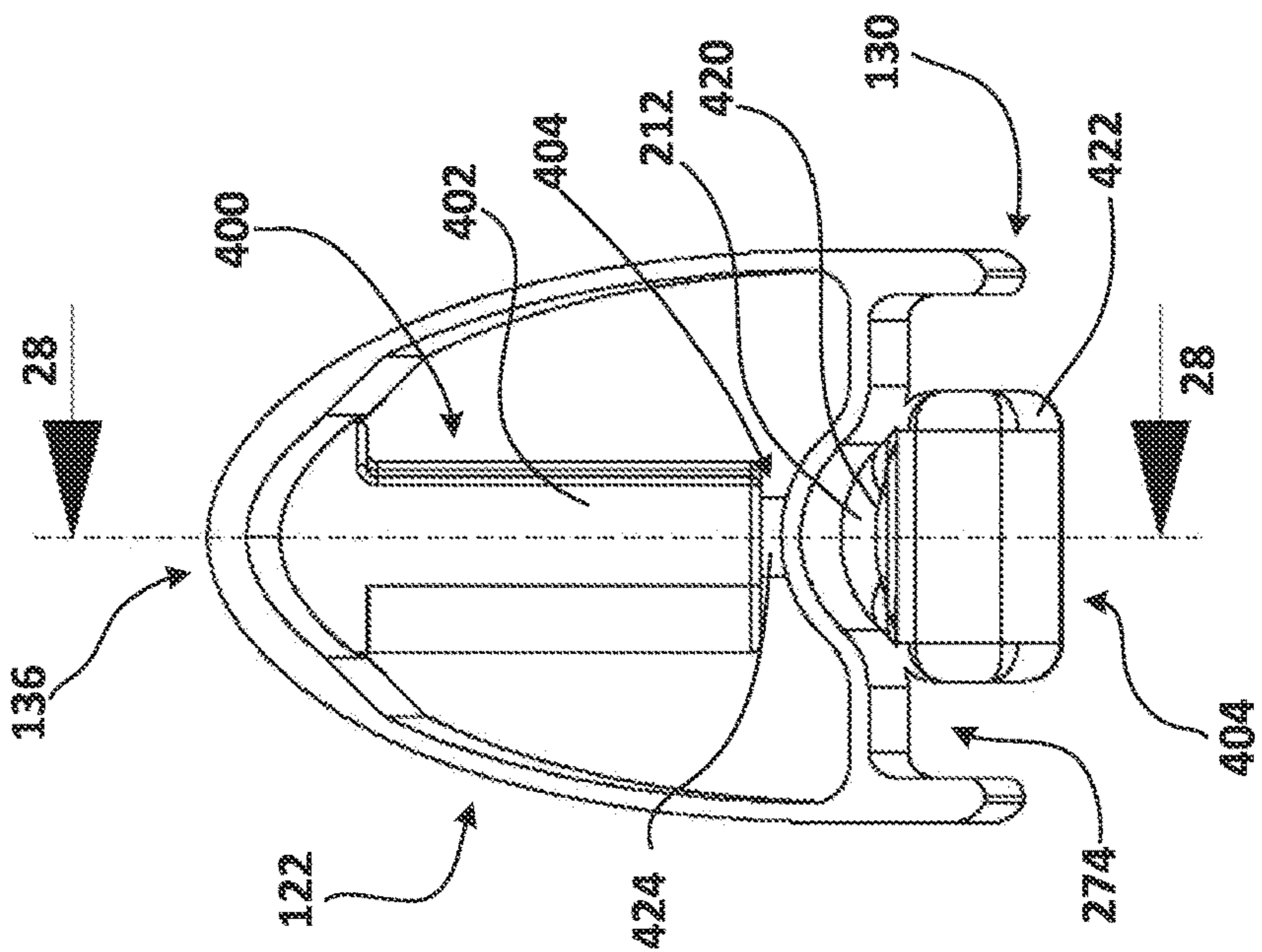

FIG. 29



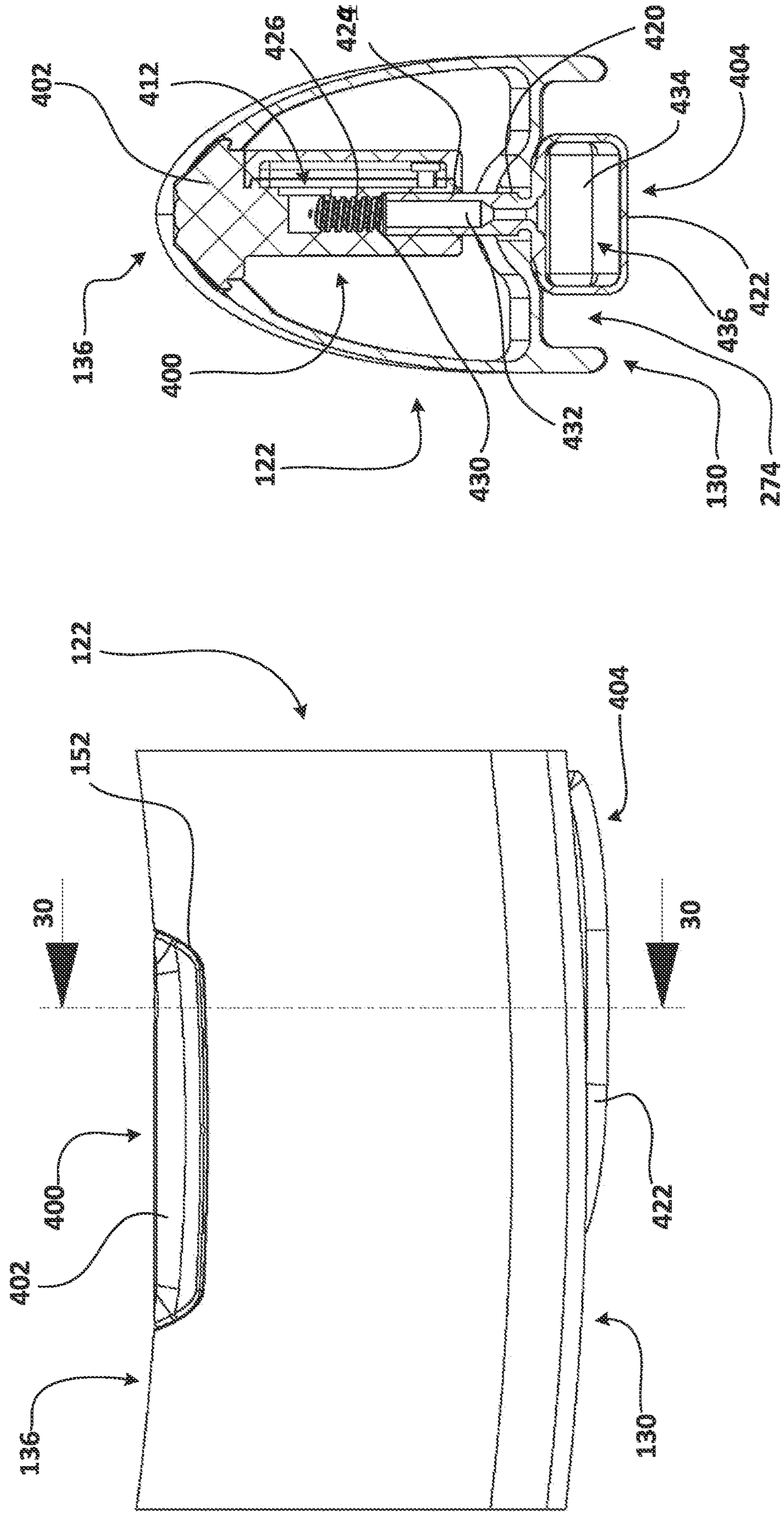

FIG. 30

FIG. 31

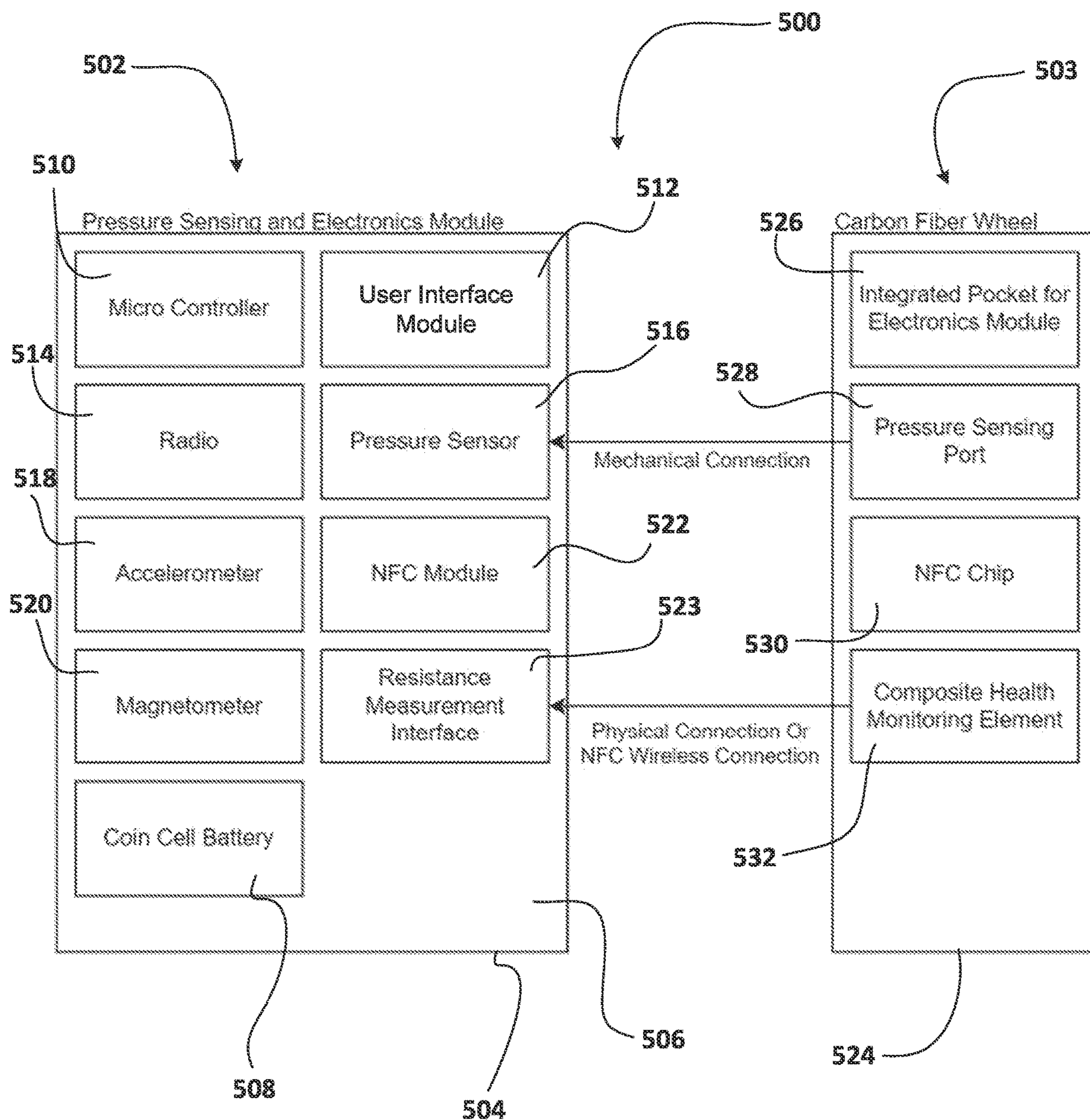

FIG. 32

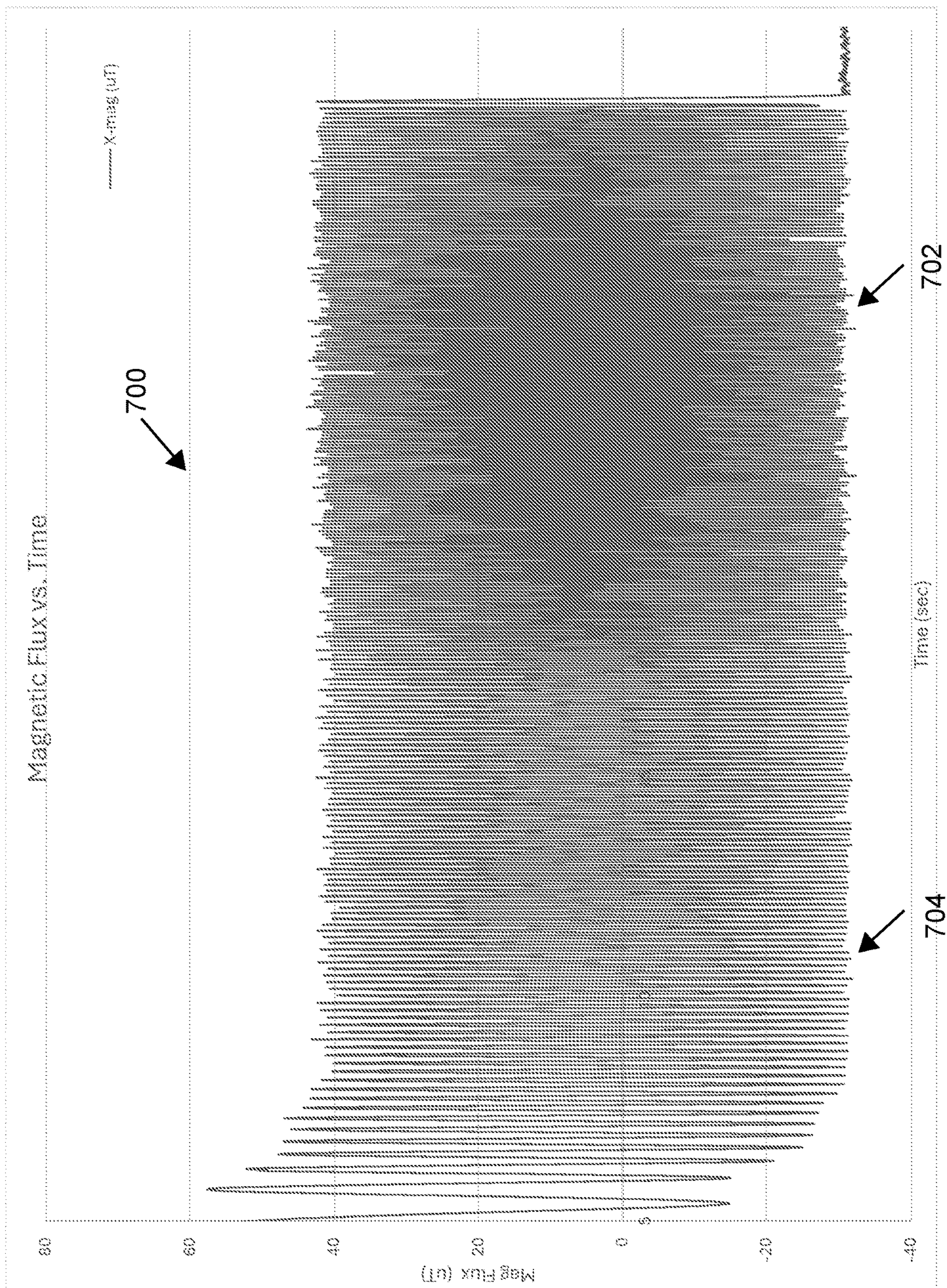

FIG. 33A

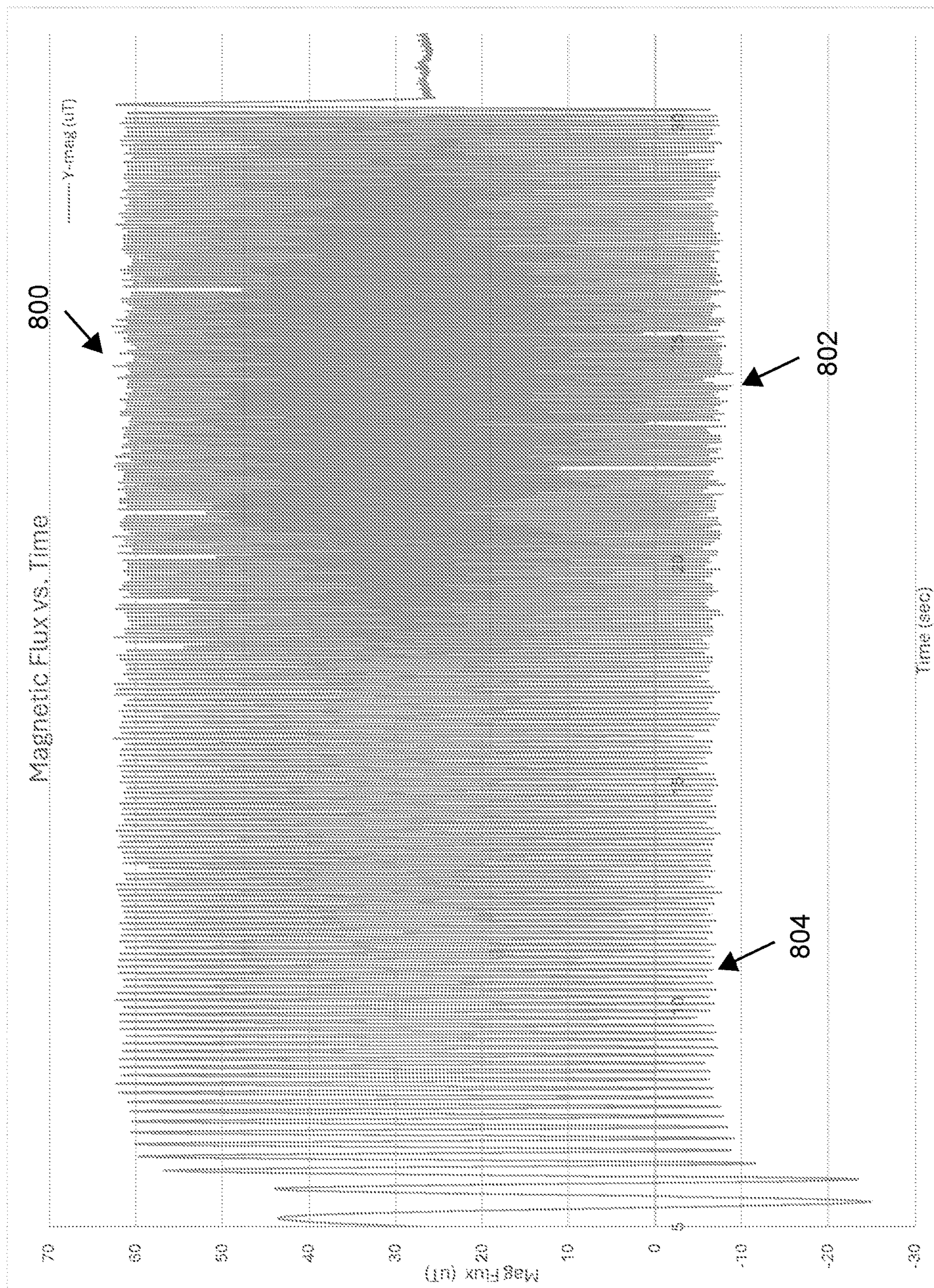

FIG. 33B

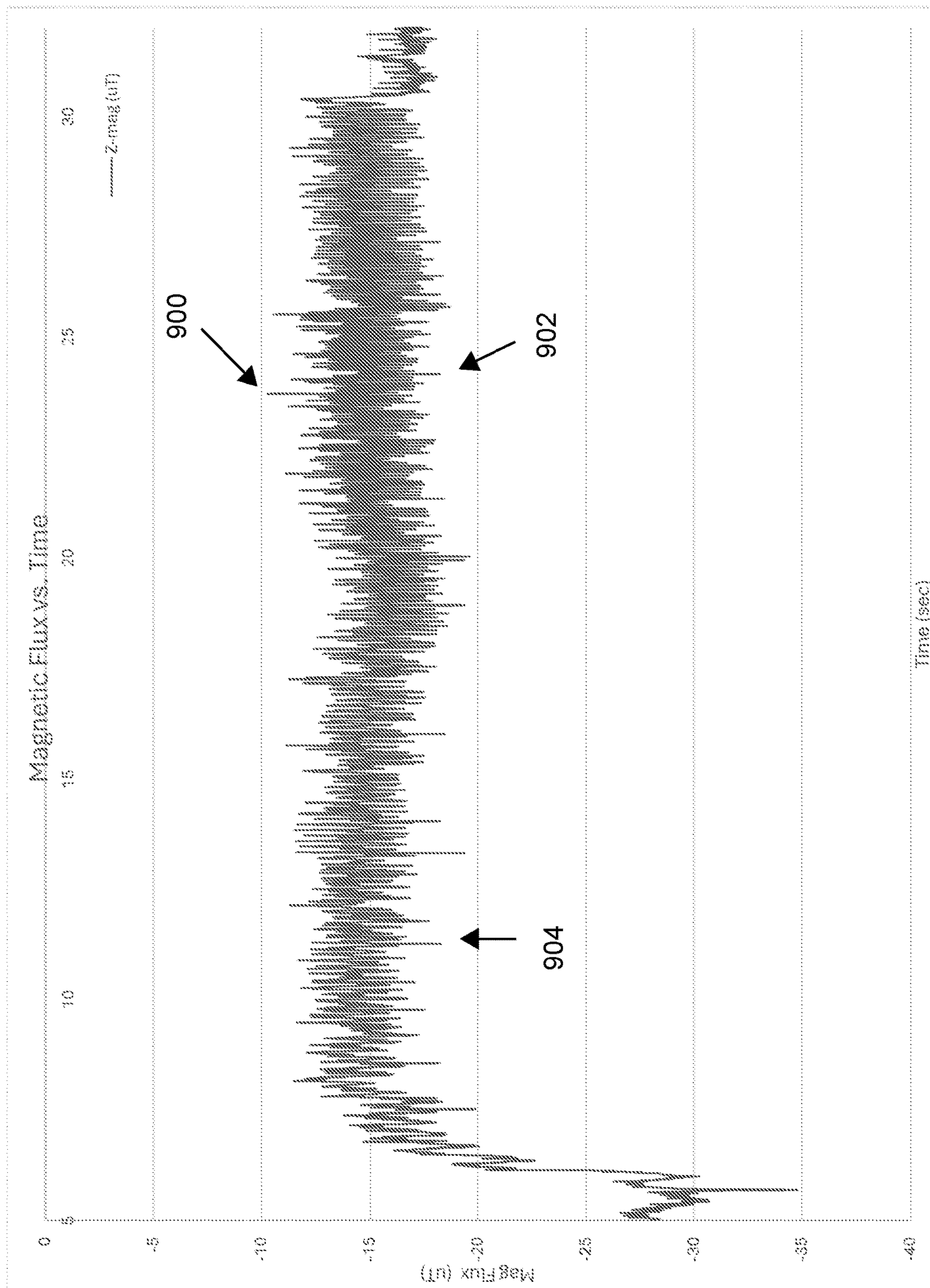

FIG. 33C

## BICYCLE WHEEL WITH AN INTEGRATED SENSOR DEVICE

**[0001]** This application claims the benefit of U.S. Provisional Application No. 63/464,220, filed May 5, 2023 and entitled “Bicycle Wheel with an Integrated Sensor Device,” the entire disclosure of which is incorporated herein by reference.

### BACKGROUND

#### 1. Field of the Disclosure

**[0002]** The present disclosure is generally directed to a rim for a bicycle wheel, and more particularly, to a rim for a bicycle wheel with an integrated sensor device.

#### 2. Description of Related Art

**[0003]** A smart wheel accessory may be attached to an outside surface of a rim or wheel. Such a smart wheel accessory may negatively influence aerodynamic drag, aesthetics, and balance of the system.

**[0004]** Alternatively, a smart wheel accessory that includes a pressure sensor may be exposed and/or anchored to an air fill valve. The air fill valve may be used to pass sealant into a tire cavity and bleed air pressure out of the tire cavity. Air bleed from the tire cavity may eject sealant through the air fill valve. Exposure of the pressure sensor to sealant may lead to clogs in a sensor port that connects the pressure sensor to the tire cavity, which may lead to inaccurate sensor measurements.

### SUMMARY

**[0005]** In one example, a rim for a bicycle wheel includes a radially inner portion disposed along an inner circumference of the rim, a first sidewall, and a second sidewall spaced apart from the first sidewall. The first sidewall and the second sidewall extend radially outward from the radially inner portion. The rim includes a radially outer tire engaging portion disposed along an outer circumference of the rim. The radially outer tire engaging portion extends from the first sidewall and the second sidewall, respectively. The rim includes an opening through the radially inner portion at a first circumferential position along the inner circumference. An air valve of the bicycle wheel is positionable through the opening. The rim includes a receptacle for a sensor device within the radially inner portion at a second circumferential position along the inner circumference. The second circumferential position is different than the first circumferential position.

**[0006]** In one example, the second circumferential position is opposite the first circumferential position.

**[0007]** In one example, the rim further includes the sensor device disposed within the receptacle and attached to the radially inner portion, the radially outer tire engaging portion, or the radially inner portion and the radially outer tire engaging portion.

**[0008]** In one example, the radially outer tire engaging portion includes a first tire retaining portion extending away from the first sidewall, and a second tire retaining portion extending away from the second sidewall, such that the first tire retaining portion and the second tire retaining portion are spaced apart from each other. The sensor device includes a housing disposed within the receptacle. The sensor device also includes a pressure sensor supported by the housing and

configured to determine a pressure of a fluid within a volume between the first tire retaining portion and the second tire retaining portion of the radially outer tire engaging portion.

**[0009]** In one example, the sensor device further includes a power source supported by the housing. The power source is accessible at the inner circumference of the rim.

**[0010]** In one example, the power source is a battery. The sensor device further includes a battery housing removably attached to the housing. The battery housing forms a portion of the inner circumference of the rim. The battery is disposable within the battery housing and configured to power the pressure sensor.

**[0011]** In one example, the pressure sensor is fluidly connected to at least a portion of the radially outer tire engaging portion.

**[0012]** In one example, the rim further includes a fastener extending through an opening through the radially outer tire engaging portion. The fastener is configured to attach the sensor device between the radially outer tire engaging portion and the radially inner portion. For example, the fastener is configured to clamp the sensor device between the external surface of the radially inner portion and the external surface of the radially outer tire engaging portion. The fastener is ported, such that a fluid passage extends through the fastener, along a length of the fastener. The pressure sensor is fluidly connected to the volume of the radially outer tire engaging portion via the fluid passage extending through the fastener when the sensor device is attached to the radially outer tire engaging portion with the fastener.

**[0013]** In one example, the rim further includes a cover configured to cover the receptacle and form part of the radially inner portion. The rim also includes a toggle bolt configured to connect the cover to the housing of the sensor device, such that the cover is pivotable relative to the housing of the sensor device. The sensor device is positionable within the rim via the receptacle. The toggle bolt is further configured to clamp the cover and the sensor device to opposite sides of the radially inner portion, respectively, at the receptacle, such that the sensor device is attached to the radially inner portion.

**[0014]** In one example, the opening is a first opening. The rim further includes a bolt that extends through a second opening. The second opening is through the radially outer tire engaging portion. The bolt is attached to the radially outer tire engaging portion at the second opening, and the bolt is ported, such that the bolt has a fluid passage extending through the bolt, along a length of the bolt. The rim further includes a flexible hose attached to the housing of the sensor device and the bolt, such that the pressure sensor is fluidly connected to the volume of the radially outer tire engaging portion via the flexible hose and the fluid passage extending through the bolt.

**[0015]** In one example, the opening is a first opening. The rim further includes a flexible container at least partially filled with the fluid. The flexible container is disposed within the volume of the radially outer tire engaging portion. The rim further includes a tube that extends through a second opening. The second opening is through the radially outer tire engaging portion. The tube is connected to the flexible container and the housing of the sensor device, such that the pressure sensor is fluidly connected to an interior of the flexible container via the tube.

**[0016]** In one example, at least part of the rim is made of a composite laminate. The rim further includes a sensing element embedded in the composite laminate. The sensor device further includes a processor in communication with the sensing element. The processor is configured to identify a change in resistance or electrical continuity of the sensing element, and identify structural characteristics (for example, structural damage, structural strain, stress, yield, and/or fracture) to the rim based on the identified change.

**[0017]** In one example, the sensing element is a wire mesh with a predetermined resistance, or an insulated electrically conductive wire. In an example, the wire may be insulated or not insulated.

**[0018]** In one example, a sensor device configured to determine a tire pressure of a wheel of a bicycle includes a housing that is disposable within a receptacle within a radially inner portion of a rim of the wheel of the bicycle, such that a portion of the housing forms part of the radially inner portion of the rim. The sensor device also includes a pressure sensor supported by the housing. The housing is connectable to a radially outer tire engaging portion of the rim, such that the pressure sensor is fluidly connected to a tire cavity of the wheel and the pressure sensor is configured to determine a pressure within the tire cavity. The sensor device includes a battery configured to power the pressure sensor, and a battery housing configured to support the battery. The battery is removably attached to the housing at the portion of the housing, such that the battery is accessible at the radially inner portion of the rim.

**[0019]** In one example, the sensor device further includes a radio-frequency identification (RFID) reader supported by the housing, and a processor supported by the housing, the processor being electrically connected to the pressure sensor, the battery, and the RFID reader. The RFID reader is configured to receive a signal from an RFID transponder disposed on or embedded within the rim when the housing of the sensor device is disposed within the receptacle. The processor is configured to identify the rim based on the received signal, and associate the determined pressure with the rim. For example, the processor identifies the rim model parameters based on the received signal and associates the rim model parameters to the pressure sensing device.

**[0020]** In one example, a bicycle wheel includes a radially inner portion disposed along an inner circumference of the rim, a first sidewall, and a second sidewall spaced apart from the first sidewall. The first sidewall and the second sidewall extend radially outward from the radially inner portion. The rim includes a radially outer tire engaging portion disposed along an outer circumference of the rim. The radially outer tire engaging portion includes a first tire retaining portion extending away from the first sidewall, and a second tire retaining portion extending away from the second sidewall, such that the first tire retaining portion and the second tire retaining portion are spaced apart from each other. The rim includes a receptacle within the radially inner portion. The bicycle wheel includes a sensor device disposed within the receptacle and attached to the radially inner portion, the radially outer tire engaging portion, or the radially inner portion and the radially outer tire engaging portion. The sensor device includes a housing and a pressure sensor supported by the housing. The bicycle wheel includes a flexible container at least partially filled with a fluid. The flexible container is disposed within a volume between the first tire retaining portion and the second tire retaining

portion of the radially outer tire engaging portion. The pressure sensor is fluidly connected to an interior of the flexible container, such that the pressure sensor is configured to determine a pressure of the fluid within the flexible container.

**[0021]** In one example, the opening is a first opening. The rim further includes a tube that extends through a second opening. The second opening is through the radially outer tire engaging portion. The tube is connected to the flexible container and the housing of the sensor device, such that the pressure sensor is fluidly connected to the interior of the flexible container via the tube.

**[0022]** In one example, the fluid is a first fluid. The determined pressure of the first fluid corresponds to a pressure of a second fluid surrounding the flexible container.

**[0023]** In one example, the first fluid is an incompressible fluid.

**[0024]** In one example, the pressure of the second fluid surrounding the flexible container is a tire pressure when a tire is attached to the rim.

#### BRIEF DESCRIPTION OF THE DRAWINGS

**[0025]** Objects, features, and advantages of the present invention will become apparent upon reading the following description in conjunction with the drawing figures, in which:

**[0026]** FIG. 1 is a side view of a bicycle that may be constructed to utilize a rim of the present disclosure;

**[0027]** FIG. 2 is a side view of a rim for a bicycle, such as the bicycle of FIG. 1, with an air valve and a sensor device installed;

**[0028]** FIG. 3 is a first front view of a portion of a rim for a bicycle, such as the bicycle of FIG. 1, with a first embodiment of a sensor device installed;

**[0029]** FIG. 4 is a first side view of the portion of the rim of FIG. 3, with the first embodiment of the sensor device installed;

**[0030]** FIG. 5 is a first perspective view of the portion of the rim of FIG. 3, with the first embodiment of the sensor device installed;

**[0031]** FIG. 6 is a second perspective view of the portion of the rim of FIG. 3, with the first embodiment of the sensor device installed;

**[0032]** FIG. 7 is a first exploded perspective view of the portion of the rim of FIG. 3;

**[0033]** FIG. 8 is a second side view of the portion of the rim of FIG. 3, with the first embodiment of the sensor device installed;

**[0034]** FIG. 9 is a cross-section of the portion of the rim of FIG. 8, taken along axis 8-8;

**[0035]** FIG. 10 is a second front view of the portion of the rim of FIG. 3, with the first embodiment of the sensor device installed;

**[0036]** FIG. 11 is a cross-section of the portion of the rim of FIG. 10, taken along axis 10-10;

**[0037]** FIG. 12 is a first cross-section of a portion of the sensor device of FIG. 3, illustrating a battery housing in an unlocked position relative to a housing of the sensor device;

**[0038]** FIG. 13 is a second cross-section of a portion of the sensor device of FIG. 3, illustrating a fluid path;

**[0039]** FIG. 14 is an exploded perspective view of a variant of the first embodiment of the sensor device of FIG. 3;

[0040] FIG. 15 is a cross-section of a portion of a rim for a bicycle, such as the bicycle of FIG. 1, with a ported bolt used for fluid connection to a sensor device attached to the rim;

[0041] FIG. 16 is a front view of a portion of a rim for a bicycle, such as the bicycle of FIG. 1, prior to attachment of a second embodiment of a sensor device to the rim;

[0042] FIG. 17 is a perspective view of the portion of the rim of FIG. 16 prior to attachment of the second embodiment of the sensor device to the rim;

[0043] FIG. 18 is a first side view of the sensor device of FIG. 16 with a cover of the sensor device in an extended position relative to a housing of the sensor device;

[0044] FIG. 19 is a second side view of the sensor device of FIG. 16 with the cover of the sensor device in the extended position relative to the housing of the sensor device;

[0045] FIG. 20 is a front view of the portion of the rim of FIG. 16, with the second embodiment of the sensor device installed;

[0046] FIG. 21 is a first side view of the sensor device of FIG. 16 with a cover of the sensor device in a contracted position relative to a housing of the sensor device;

[0047] FIG. 22 is a second side view of the sensor device of FIG. 16 with the cover of the sensor device in the contracted position relative to the housing of the sensor device;

[0048] FIG. 23 is a cross section of a portion of the sensor device of FIG. 16, illustrating a fluid path;

[0049] FIG. 24 is a first perspective view of a portion of a rim for a bicycle, such as the bicycle of FIG. 1, with a third embodiment of a sensor device installed;

[0050] FIG. 25 is a second perspective view of the portion of the rim of FIG. 24, with the third embodiment of the sensor device installed;

[0051] FIG. 26 is a bottom view of the portion of the rim of FIG. 24, with the third embodiment of the sensor device installed;

[0052] FIG. 27 is a top view of the portion of the rim of FIG. 24, with the third embodiment of the sensor device installed;

[0053] FIG. 28 is a front view of the portion of the rim of FIG. 24, with the third embodiment of the sensor device installed;

[0054] FIG. 29 is a cross-section of the portion of the rim of FIG. 28, taken along axis 28-28;

[0055] FIG. 30 is a side view of the portion of the rim of FIG. 24, with the third embodiment of the sensor device installed;

[0056] FIG. 31 is a cross-section of the portion of the rim of FIG. 30, taken along axis 30-30;

[0057] FIG. 32 is a schematic diagram of a rim assembly including a sensor device;

[0058] FIG. 33a is a plot of magnetometer output over time;

[0059] FIG. 33b is a plot of magnetometer output over time; and

[0060] FIG. 33c is a plot of magnetometer output over time.

the sensor device is positioned within a cavity within a rim of the bicycle wheel. The sensor device includes a number of electronic components configured to measure data and transmit the data to a computing device such as, for example, a mobile phone or a bicycle computer for communication (e.g., display) to a user. The measured data may include, for example, tire pressure data, wheel speed data, wheel odometer data, rim composite health data, wheel lean and yaw data, product data, road feedback data, light emitting diode (LED) status indicators, and/or other data.

[0062] The receptacle may have a complementary interface with the sensor device, such that the receptacle occludes the sensor device to improve aerodynamic performance. The receptacle may be within a radially inner portion of the rim. For example, the rim may be manufactured with a reinforced opening forming the receptacle (e.g., a cavity) within the radially inner portion of the rim. The sensor device may be inserted into the cavity and anchored to the radially inner portion of the rim and/or a radially outer tire engaging portion of the rim. The sensor device may be anchored to the rim, such that the sensor device is removable from the rim without having to remove a tire from the rim. In one embodiment, a battery housing, and a battery supported within the battery housing, may be accessible without removing the sensor device from the rim.

[0063] The sensor device may be anchored to the radially inner portion of the rim and/or a radially outer tire engaging portion of the rim in a number of different ways. In one embodiment, the sensor device is anchored with a bolt that also acts as a pressure port to the tire chamber. In another embodiment, the sensor device may be attached to the radially inner portion of the rim without relying on the radially outer tire engaging portion of the rim for support. In this embodiment, a separate pressure port may be installed within the radially outer tire engaging portion of the rim to relay the pressure to the sensor device. This may be done using rigid or flexible materials. The anchoring of the sensor device to the rim provides a fluid connection between a pressure sensor port of the sensor device and the tire chamber that is blind. This reduces the likelihood of sealant obstruction of the sensor port.

[0064] The receptacle, and thus the sensor device, may be positioned opposite the air fill valve. Separating the air fill valve from a sensor port for a pressure sensor of the sensor device helps reduce exposure of the sensor port to sealant, which reduces or prevents clogging of the sensor device by sealant. Positioning the sensor device opposite the air fill valve instead of on the air fill valve may help rebalance the wheel for optimum performance and allows for any weight of the sensor device to be compensated for on the air fill valve side. This allows the sensor device to house larger batteries and execute more functions for a given battery life. Further, design constraints are relieved by dissociating the pressure sensor from the air fill valve, which allows for the selection of an appropriate air fill valve. For example, the air fill valve may be selected for optimal air fill characteristics.

[0065] In one embodiment, the sensor device includes a printed circuit board (PCB) that supports a pressure sensor coupled to a tube. The tube connects to a pouch filled (e.g., partially filled) with incompressible fluid. The fluid-filled pouch is exposed to tire pressure in the tire cavity and transmits the pressure to the sensor via a fluid path along the tube. The tube transmitting the pressure between the pouch and the pressure sensor may be any arbitrary length, which

#### DETAILED DESCRIPTION OF THE DISCLOSURE

[0061] In order to improve aerodynamic drag performance and balance of a bicycle wheel that includes a sensor device,



allows for optimal placement of the sensor device and/or the pouch to best suit wheel design requirements.

**[0066]** A bicycle wheel of one or more of the present embodiments includes, for example, a rim including a radially inner portion disposed along an inner circumference of the rim, a first sidewall, and a second sidewall spaced apart from the first sidewall. The first sidewall and the second sidewall extend radially outward from the radially inner portion. The rim includes a radially outer tire engaging portion disposed along an outer circumference of the rim. The radially outer tire engaging portion includes a first tire retaining portion extending from the first sidewall, and a second tire retaining portion extending away from the second sidewall, such that the first tire retaining portion and the second tire retaining portion are spaced apart from each other. The rim includes a receptacle within the radially inner portion. The bicycle wheel includes a sensor device disposed within the receptacle and attached to the radially inner portion, the radially outer tire engaging portion, or the radially inner portion and the radially outer tire engaging portion. The sensor device includes a housing and a pressure sensor supported by the housing. The bicycle wheel includes a flexible container at least partially filled with a fluid. The flexible container is disposed within a volume between the first tire retaining portion and the second tire retaining portion of the radially outer tire engaging portion. The pressure sensor is fluidly connected to an interior of the flexible container, such that the pressure sensor is configured to determine a pressure of the fluid within the flexible container. In an example, the fluid may be a gas or liquid.

**[0067]** Wireless communication between components is described herein. Although the present specification describes components and functions that may be implemented in particular wireless communication embodiments with reference to particular standards and protocols, the invention is not limited to such standards and protocols. For example, standards for Internet and other packet switched network transmission (e.g., TCP/IP, UDP/IP, HTML, HTTP, HTTPS) represent examples of the state of the art. Such standards are periodically superseded by faster or more efficient equivalents having essentially the same functions. Accordingly, replacement standards and protocols having the same or similar functions as those disclosed herein are considered equivalents thereof.

**[0068]** In an embodiment, components of the bicycle described herein will communicate with each other. In the case of wireless communication, the components will initially be paired so as to allow secure communication between components on the bicycle without interference from devices not associated with the system. One or more of the components may also be paired with a separate device such as a computer, tablet, or phone (e.g., a mobile computing device). This paired device may provide the user interface to allow the user to communicate with the components on the bicycle. Examples of communication are updating firmware, setting variables, and running diagnostic tools and analysis.

**[0069]** These and other objects, features, and advantages of the disclosed bicycle component control will become apparent to those having ordinary skill in the art upon reading this disclosure. Throughout the drawing figures, where like reference numbers are used, the like reference numbers represent the same or substantially similar parts among the various disclosed examples. Also, specific

examples are disclosed and described herein that utilize specific combinations of the disclosed aspects, features, and components of the disclosure. However, it is possible that each disclosed aspect, feature, and/or component of the disclosure may, in other examples not disclosed or described herein, be used independent of or in different combinations with other of the aspects, features, and components of the disclosure.

**[0070]** Turning now to the drawings, FIG. 1 generally illustrates a bicycle 50 that employs one or more components (e.g., rims) constructed in accordance with the teachings of the present disclosure. The bicycle 50 includes a frame 52 (e.g., a bicycle frame), a front wheel 54 and a rear wheel 56 each rotatably attached to the frame 52, and a drivetrain 58. A front brake 60 is provided for braking the front wheel 54, and a rear brake 62 is provided for braking the rear wheel 56. The bicycle 50 also generally has a seat 64 near a rear end of the frame 52 and carried on an end of a seat post 66 connected to the frame 52. The bicycle 50 also has handlebars 68 near a forward end of the frame 52. A brake lever 70 is carried on the handlebars 68 for actuating the front brake 60, the rear brake 62, or both the front brake 60 and the rear brake 62. If the brake lever 70 actuates only one of the front brake 60 and the rear brake 62, a second brake lever (not shown) may also be provided to actuate the other brake. A front and/or forward riding direction or orientation of the bicycle 50 is indicated by the direction of the arrow A in FIG. 1. As such, a forward direction for the bicycle 50 is indicated by the direction of arrow A. While the illustrated bicycle 50 depicted in FIG. 1 is a road bike having drop-style handlebars 68, the present disclosure may be applicable to bicycles of any type, including mountain bikes with full or partial suspensions.

**[0071]** The drivetrain 58 has a chain C and a front sprocket assembly 72, which is coaxially mounted with a crank assembly 74 (e.g., including two crank arms) having pedals 76. The drivetrain 58 also includes a rear sprocket assembly 78 coaxially mounted with the rear wheel 56 and a rear gear change mechanism, such as a rear derailleur 80 (e.g., an electric rear derailleur).

**[0072]** As is illustrated in FIG. 1, the front sprocket assembly 72 may include one or more coaxially mounted chainrings, gears, or sprockets. In this example, the front sprocket assembly 72 has one sprocket F. The one sprocket F has teeth 82 around a respective circumference. As shown in FIG. 1, the rear sprocket assembly 78 may include a plurality of coaxially mounted gears, cogs, or sprockets G. Each sprocket G1-G8 also has teeth 84 arranged around a respective circumference. The number of teeth 84 on the rear sprockets G1-G8 may gradually decrease from the largest diameter rear sprocket G1 to the smallest diameter sprocket G8. Though not described in any detail herein, a front gear changer 85 may be operated to move from a first operating position to a second operating position to move the chain C between front sprockets F. Likewise, the rear derailleur 80 may be operable to move between different operating positions to switch the chain C to a selected one of the rear sprockets G1-G8. In an embodiment, the rear sprocket assembly 78 may have more or fewer sprockets G. For example, in an embodiment, the rear sprocket assembly 78 may have eleven, twelve or thirteen sprockets. Dimensions and configuration of the rear derailleur 80 may be modified to accommodate a specific implemented plurality of sprockets. For example, an angle and length of a linkage and/or a

configuration of a cage of the rear derailleur **80** may be modified to accommodate specific sprocket combinations.

[0073] The rear derailleur **80** is depicted as a wireless, electrically actuated rear derailleur mounted or mountable to the frame **52**, or frame attachment, of the bicycle **50**. The electric rear derailleur **80** has a base member **86** (e.g., a b-knuckle) that is mounted to the bicycle frame **52**. A linkage **88** has two links L that are pivotally connected to the base member **86** at a base member linkage connection portion. A movable member **90** (e.g., a p-knuckle) is connected to the linkage **88** at a moveable member linkage connection portion. A chain guide assembly **92** (e.g., a cage) is configured to engage and maintain tension in the chain and has one or more cage plates **93** with a proximal end that is pivotally connected to a part of the movable member **90**. The cage plate **93** may rotate or pivot about a cage rotation axis in a damping direction and a chain tensioning direction. Other gear changing systems, such as mechanically or hydraulically controlled and/or actuated systems may also be used.

[0074] A motor module may be carried on the electric rear derailleur **80** with a battery. The battery supplies power to the motor module. In one example, the motor module is located in the movable member **90**. However, the motor module may instead be located elsewhere, such as in one of the links L of the linkage **88** or in the base member **86**. The motor module may include a gear mechanism or transmission. As is known in the art, the motor module and gear mechanism may be coupled with the linkage **88** to laterally move the cage plate **93** and thus switch the chain C among the rear sprockets (e.g., G1-G8) on the rear sprocket assembly **78**.

[0075] The cage plate **93** also has a distal end that carries a tensioner cog or wheel. The wheel also has teeth around a circumference. The cage plate **93** is biased in a chain tensioning direction to maintain tension in the chain C. The chain guide assembly **92** may also include a second cog or wheel, such as a guide wheel disposed nearer the proximal end of the cage plate **93** and the movable member **90**. In operation, the chain C is routed around one of the rear sprockets (e.g., G1-G8). An upper segment of the chain C extends forward to the front sprocket assembly **72** and is routed around the one front sprocket F. A lower segment of the chain C returns from the front sprocket assembly **72** to the tensioner wheel and is then routed forward to the guide wheel. The guide wheel directs the chain C to the rear sprockets (e.g., G1-G8). Lateral movement of the cage plate **93**, the tensioner wheel, and the guide wheel may determine the lateral position of the chain C for alignment with a selected one of the rear sprockets (e.g., G1-G8).

[0076] The bicycle **50** may include one or more bicycle control devices **96** (e.g., a bicycle control device) mounted to handlebars **68**. The one or more bicycle control devices may include one or more types of bicycle control and/or actuation systems. For example, the one or more bicycle control devices **96** may include brake actuation systems to control the front brake **60** and/or the rear brake **62**, and/or gear shifting systems to control the drivetrain **58**. Other control systems may also be included. For example, the system may be applied, in some embodiments, to a bicycle where only a front or only a rear gear changer is used. Also, the one or more bicycle control devices may also include suspension, seat post, and/or other control systems for the bicycle **50**.

[0077] The front wheel **54** and/or the rear wheel **56** of the bicycle **50** may include a tire **120** attached to a radially outer tire engaging portion of a rim **122**. A plurality of spokes **124** are attached directly to the rim **122**. Alternatively, the spokes **124** may be attached and/or secured to the rim **122** with other structural components. The spokes **124** extend from the rim **122** and attach to a central hub **126**. The spokes **124** are maintained with a tension between the rim **122** and the central hub **126** to provide the respective wheel **54**, **56** with an operational rigidity for use on the bicycle **50**. The central hub **126** is configured for rotational attachment to the bicycle frame **52**.

[0078] FIG. 2 illustrates a rim **122** for a bicycle wheel, such as the front wheel **54** of FIG. 1, removed from the rest of the bicycle **50**, without a tire attached, and without spokes (e.g., spokes **124** of FIG. 1) or a hub (e.g., a central hub **126** of FIG. 1). The rim **122** includes a tire engaging portion **130** to engage with the tire **120**, as is shown in FIG. 1. The tire engaging portion **130** is configured radially outward of a spoke receiving surface **132** that is disposed along an inner circumference **134** of the rim **122**. In other words, the tire engaging portion **130** is a radially outer tire engaging portion. In an embodiment, the tire engaging portion **130** is disposed along an outer circumference **135** of the rim **122**. The tire engaging portion **130** is configured for attachment to tires using clincher tire attachment configurations for tires including beaded interlock attachments. Other configurations of the tire engaging portion **130** may also be provided to allow for the use of other types of tires on the rim **122**. For example, tubeless tires including beaded interlock attachment types may be used.

[0079] The rim **122** provides structure for attachment of the spokes to the rim **122** at a receiving portion of the rim **122**, proximate to the spoke receiving surface **132**. As such, the spoke receiving surface **132** is part of a spoke engaging portion **136** (e.g., a radially inner portion) of the rim **122**. In an embodiment, the spoke engaging portion **136** of the rim **122** is disposed along the inner circumference **134** of the rim **122**. In another embodiment, the spoke receiving surface **132** and the spoke engaging portion **136** may be separate parts and/or portions of the rim **122**. For example, the spokes may pass through the spoke receiving surface **132**, and the structure for attachment to the rim **122** may be provided proximate to the tire engaging portion **130**.

[0080] The rim **122** includes a first sidewall **138** and a second sidewall **206** that extend between the tire engaging portion **130** and the spoke engaging portion **136**. For example, the first sidewall **138** and the second sidewall **206** extend radially outward from the spoke engaging portion **136** to the tire engaging portion **130**. The first sidewall **138** is spaced apart from the second sidewall **206**. The rim **122** may be hollow between, for example, the first sidewall **138**, the second sidewall **206**, the tire engaging portion **130**, and the spoke engaging portion **136**.

[0081] At least part of the rim **122** (e.g., the first sidewall **138** and the second sidewall **206**) is formed by one or more composite materials. In one embodiment, the entire rim **122** is formed by one or more composite materials. In one example, fiber reinforced plastic forms a one-piece unitary rim of a collection of layers including the tire engaging portion **130**, the first sidewall **138**, the second sidewall **206**, and the spoke engaging portion **136**. Other configurations may also be provided. For example, a combination of plastic and carbon-fiber reinforced plastic forms a one-piece unitary

rim of a collection of plastic layers and carbon-fiber layers including the tire engaging portion 130, the first sidewall 138, the second sidewall 206, and the spoke engaging portion 136. Other configurations may also be provided.

[0082] The rim 122, for example, may be at least partially formed by a laminate that includes one or more compressed layers of one or more materials. Any number of materials may be included within the laminate including, for example, a thermoplastic and/or a thermoplastic with reinforcing fiber material (e.g., bendable fabric preform sheets). The reinforcing fiber material may be any number of reinforcing materials including, for example, Nylon. More, fewer, and/or different materials may be included within the laminate. For example, the reinforcing fiber material may be a natural fiber such as, for example, flax.

[0083] The front wheel 54 and the rear wheel 56 may include rims 122 configured for any size wheel. In an embodiment, the rims 122 are configured for use in wheels conforming to a 700C (e.g., a 622 millimeter diameter clincher and/or International Standards Organization 622 mm) bicycle wheel standard.

[0084] The front wheel 54 and the rear wheel 56 may rotate about the central hub 126 in either direction. For example, as shown in FIG. 1, the front wheel 54 and the rear wheel 56 may be configured to rotate in a particular rotational direction about the central hub 126. In another example, the front wheel 54 and the rear wheel 56 may be configured to rotate in a direction opposite the particular rotational direction.

[0085] In one embodiment, the first sidewall 138, the second sidewall 206, the spoke engaging portion 136, and the tire engaging portion 130 of the front wheel 54 and/or the rear wheel 56 of the bicycle 50 (e.g., the front wheel 54 and the rear wheel 56 in the example of FIG. 1) are at least partially formed by one or more layers of the one or more composite materials (e.g., layers of composite materials). Each of the one or more layers may include one or more fabric plies (e.g., pieces) of the respective composite material. Different layers of different composite materials may include different numbers of plies or pieces of the composite materials, respectively. At least some of the layers of composite material may be of different shapes and/or sizes. Alternatively, all of the layers of the composite material may be a same shape and/or size.

[0086] In one embodiment, at least some of the layers of composite material are shaped as strips. For example, strips of the one or more composite materials may form the first sidewall 138 and the second sidewall 206 of the front wheel 54. The strips of the one or more composite materials may be disposed about the central hub 126 of the front wheel 54, respectively, and the central hub 126 of the rear wheel 56, respectively, to form the first sidewall 138 and the second sidewall 206 of the front wheel 54 and the rear wheel 56, respectively.

[0087] In a manufacturing process, the layers of the front wheel 54 and the rear wheel 56, respectively, are integrated with the spoke engaging portion 136 and the tire engaging portion 130 (e.g., layers of composite material forming the spoke engaging portion 136 and the tire engaging portion 130) of the respective wheel 54, 56 by, for example, a curing process, such that a one-piece unitary rim 122 is formed. The rims 122 of the front wheel 54 and rear wheel 56, respectively, may be formed with other manufacturing processes.

[0088] The rim 122 of FIG. 2 illustrates a valve 140 (e.g., an air valve) extending through the spoke engaging portion 136 (e.g., the radially inner portion) and away from the tire engaging portion 130 of the rim 122. The valve 140 may be any number of different types of valves for inflation and/or deflation of a tire (e.g., the tire 120) including, for example, a Schrader valve, a Presta valve, or a Woods valve.

[0089] The radially inner portion 136 of the rim 122 includes an opening 144 that extends through the radially inner portion 136 of the rim 122 at a first position 146 along the inner circumference 134 (e.g., a first circumferential position 146). The valve 140 extends through the opening 144, away from the radially inner portion 136 and the tire engaging portion 130 of the rim 122. The opening 144 may be any number of sizes and/or shapes. For example, the opening 144 may be circular in shape and may be sized, such that an outer surface of the valve 140 abuts a surface of the radially inner portion 136 that forms the opening 144. In one embodiment, the opening 144 has a diameter of approximately 7 mm. In other embodiments, the diameter of the opening 144 is larger or smaller.

[0090] The rim 122 of FIG. 2 also illustrates a sensor device 150 installed within the rim 122. The sensor device 150 may be configured to measure and/or determine data that may be useful to a rider of the bicycle 50, for example, and transmit the data to a computing device (e.g., of the bicycle 50 or a mobile computing device off of the bicycle 50), for example, for display to the rider. For example, the sensor device 150 may transmit the data to the bicycle control device 96 for display to the rider and/or further processing. The sensor device 150 may include any number of electronic components and may measure and/or determine any number of different types of data associated with the rim 122 and/or the bicycle 50, for example. For example, the sensor device 150 may measure and/or determine, for example, tire pressure data, wheel speed data, wheel odometer data, data related to rim composite health, wheel lean and yaw data, product data, road feedback data, LED status indicators, one or more other types of data, or any combination thereof.

[0091] The radially inner portion 136 of the rim 122 includes a receptacle 152 (e.g., a cavity) within the radially inner portion 136 of the rim 122 at a second position 154 along the inner circumference 134 (e.g., a second circumferential position 154). The sensor device 150 may be positioned within the receptacle 152 and attached to the rim 122, such that part of the sensor device 150 forms a portion of the radially inner portion 136 (e.g., the inner circumference 134) of the rim 122. For example, the receptacle 152 may occlude the sensor device 150, such that aerodynamic performance and aesthetics are improved compared to prior art sensor devices installed at a valve.

[0092] The receptacle 152 may be any number of shapes and/or sizes. For example, the receptacle 152 may be large enough to accommodate a sensor device 150 that includes one or more sensors, one or more batteries, a processor, a memory, other electronic devices, or any combination thereof, but small enough to fit within an area between two adjacent spokes of a wheel (e.g., approximately 150 mm) on which the rim 122 is used. In one embodiment, a length (e.g., an arc length) of the receptacle 152 is less than or equal to 70 mm. In other embodiments, however, larger receptacles 152 may be provided.

[0093] The second circumferential position **154** along the inner circumference **134**, at which the receptacle **152** is positioned, is different than the first circumferential position **146** along the inner circumference **134**, at which the opening **144** extends through the radially inner portion **136** of the rim **122**. In other words, the sensor device **150** is positioned at a distance away from (e.g., is remote relative to) the valve **140**.

[0094] In one embodiment, the second circumferential position **154** along the inner circumference **134** is opposite the first circumferential position **146** along the inner circumference **134**. In other words, in such an embodiment, the sensor device **150** is opposite the valve **140** (e.g., on opposite sides of the inner circumference **134** of the rim **122**). By positioning the sensor device **150** opposite the valve **140**, a wheel on which the rim **122** is installed (e.g., the wheel **54** or **56**) may be rebalanced for optimum performance: any weight added by the sensor device **150** at the second circumferential position **154** (e.g., relative to a rim without an installed sensor device **150**) may be compensated for (e.g., counterbalanced) at the valve **140**. This ability to balance weight at opposite sides of the inner circumference **134** of the rim **122** allows the sensor device **150** to include larger batteries and execute more functions for a give battery life. This also allows the valve **140** to be selected for optimal air fill characteristics. Separating the valve **140** from sensors helps reduce exposure of the sensor to sealant, which may clog the sensors.

[0095] The receptacle **152** may be configured in any number of ways, such that attachment of the sensor device **150** to the rim **122** at the receptacle **152** is secure, and the sensor device **150** is flush with the radially inner portion **136** of the rim **122**. For example, the rim **122** may be structurally reinforced around the receptacle **152** (e.g., with a thicker composite laminate around the receptacle **152**). The rim **122** may be structurally reinforced around the receptacle **152** with a same material the rim **122** is made of (e.g., a composite material), or one or more other materials. As another example, the receptacle **152** may have a complementary interface (e.g., corresponding flanges) with the sensor device **150** (e.g., a housing of the sensor device **150**) to allow secure attachment of the sensor device **150** to the rim **122** at the receptacle **152**.

[0096] A sensor (e.g., a pressure sensor) of the sensor device **150** has a sensor port (e.g., a pressure sensor port) that is exposed to a portion of the rim that is remote from (e.g., at a distance relative to) the sensor device **150**. For example, the pressure sensor port of the pressure sensor is fluidly connected to a tire bed at the tire engaging portion **130** of the rim **122**, such that the pressure sensor may measure a tire pressure when the tire **120** is installed on the rim **122**. In other words, the pressure sensor port is blind, which reduces a likelihood of sealant obstruction of the sensor port. The pressure sensor port of the pressure sensor may be fluidly connected to the tire bed at the tire engaging portion **130** of the rim **122**, for example, in any number of ways. The configuration of this fluid connection may depend on how the sensor device **150** is attached to the rim **122**. The embodiments discussed below illustrate different attachments to the rim **122** and/or different fluid connections.

[0097] FIGS. 3-14 illustrate a sensor device **200** that may be attached (e.g., mounted) to the rim **122** and fluidly

connected to, for example, a volume defined by the tire engaging portion **130** of the rim **122**, according to a first embodiment.

[0098] Referring to FIG. 3, the radially outer tire engaging portion **130** includes a first tire retaining portion **202** and a second tire retaining portion **204** spaced apart from the first tire retaining portion **202**. The first tire retaining portion **202** extends from the first sidewall **138**, and the second tire retaining portion **204** extends from a second sidewall **206**. The first sidewall **138** and the second sidewall **206** extend radially inward from the radially outer tire engaging portion **130**.

[0099] The first tire retaining portion **202** includes a first tire retaining wall **208**. In one embodiment, the first tire retaining portion **202** also includes a first protrusion (e.g., a first tire retaining feature) (not shown). The first protrusion may extend away from the first tire retaining wall **208**. The first protrusion may be any number of shapes including, for example, a shape having a cross-section that is rectangular with a semi-circle cap. The first protrusion may extend circumferentially around the rim **122**.

[0100] The second tire retaining portion **204** includes a second tire retaining wall **210**. The second tire retaining wall **210** is opposite and spaced apart from the first tire retaining wall **208**. In one embodiment, the second tire retaining portion **204** also includes a second protrusion (e.g., a second tire retaining feature) (not shown). The second protrusion may extend away from the second tire retaining wall **210**, towards the first tire retaining portion **202**. The second protrusion may be any number of shapes including, for example, a shape having a cross-section that is rectangular with a semi-circle cap. The second protrusion may extend circumferentially around the rim **122**. The first protrusion and the second protrusion may be other shapes.

[0101] The rim **122** may seat a tire **120** (see FIG. 1) that is, for example, a tubeless clincher tire. The tire **120** includes beads that interact with the radially outer tire engaging portion **130** (e.g., the first tire retaining portion **202** and the second tire retaining portion **204**) of the rim **122** to attach the tire **120** to and maintain the tire **120** on the rim **122**. The beads may include any number of materials within the beads, such as, for example, carbon, a steel wire or aramid (e.g., Kevlar™) fiber, to prevent the tire **120** from moving off of the rim **122**. Due to the reinforcement with the carbon, steel wire or the Kevlar™ fiber, for example, the beads resist stretching from internal air pressure. Alternatively, the beads may be made of a same material as the tire **120** (e.g., rubber).

[0102] The radially outer tire engaging portion **130** also includes a well **212** positioned between the first tire retaining portion **202** and the second tire retaining portion **204** of the rim **122**. The well **212** provides a volume into which the beads of the tire **120** may be placed when the tire **120** is being attached to the rim **122**. As the tire **120** is inflated, the beads of the tire **120** move away from each other until the beads interact with the first tire retaining portion **202** and the second tire retaining portion **204**, respectively. When inflated, the beads of the tire **120** abut the first tire retaining wall **208** and the second tire retaining wall **210**, respectively. In one embodiment, the first tire retaining feature and the second tire retaining feature, for example, keep the beads of the tire **120** positioned within the radially outer tire engaging portion **130** (e.g., keep the beads of the tire **120** engaged with the first tire retaining wall **208** and the second tire retaining wall **210**) and thus keep the tire **120** from blowing off the rim

**122.** The contact between the beads and the first tire retaining wall **208** and the second tire retaining wall **210**, respectively, forms a seal between the inflated tire **120** and the rim **122**.

**[0103]** The radially outer tire engaging portion **130** may also include ridges (e.g., bead bumps; a first bead bump and a second bead bump) on opposite sides of the well **212**, respectively. A first shelf **214** (e.g., a first bead shelf) extends away from the first tire retaining wall **208** (e.g., between the first tire retaining wall **208** and the first bead bump), and a second shelf **216** (e.g., a second bead shelf) extends away from the second tire retaining wall **210** (e.g., between the second tire retaining wall **210** and the second bead bump). In one embodiment, curved transition regions **218** extend between the first shelf **214** and the first tire retaining wall **208**, and the second shelf **216** and the second tire retaining wall **210**, respectively. The bead bumps may be positioned on opposite sides of the well **212**, respectively, and may be raised relative to the first shelf **214** and the second shelf **216**, respectively. The bead bumps may help retain the tire **120** on the rim **122** if the tire **120** loses pressure.

**[0104]** As shown in FIG. 3, the rim **122** is hollow, and a shape of a volume **220** within the rim **122** may be defined by the first sidewall **138**, the second sidewall **206**, the radially outer tire engaging portion **130** (e.g., the well **212**, the first shelf **214**, and the second shelf **216**), and the radially inner portion **136**. The volume **220** may be any number of sizes and/or shapes. When the sensor device **200** is installed in (e.g., attached to) the rim **122**, at least a portion of the sensor device **200** is positioned within the volume **220**.

**[0105]** Referring to FIG. 7, the sensor device **200** includes a housing **222** and a battery housing **224**. The receptacle **152** at the radially inner portion **136** of the rim **122** is formed by an opening **226** through the radially inner portion **136** of the rim **122**, and a flange **228** that extends around the opening **226**. The housing **222** of the sensor device **200** includes a cover **230** having a flange **232** that corresponds to (e.g., sized and shaped to interface with) the flange **228** of the receptacle **152**, such that when the housing **222** of the sensor device **200** is installed on the rim **122**, the cover **230** of the housing **222** of the sensor device **200** is flush with the radially inner portion **136** of the rim **122**.

**[0106]** The housing **222** of the sensor device **200** supports any number of components (e.g., electronic components) of the sensor device **200**. For example, the housing **222** of the sensor device **200** supports the battery housing **224**. Referring to FIG. 3, the housing **222** also supports a printed circuit board (PCB) **234**, on which any number of electronic components may be disposed and electrically connected. As will be discussed in more detail below, referring to FIG. 3, the PCB **234** may support and electrically connect one or more processors (e.g., a microcontroller) **235a**, a light emitting diode (LED) **235b**, one or more antennas (e.g., a radio) **235c**, one or more sensors **235d** (e.g., a pressure sensor, an accelerometer, a magnetometer, and/or a resistance measurement interface), one or more power sources **235e**, a radio-frequency identification (RFID) reader **235f** (e.g., a near field communication (NFC) reader or module), one or more other electronic components, or any combination thereof. The PCB **234** may support and electrically connect more, fewer, and/or different components of the sensor device **200**.

**[0107]** The housing **222** of the sensor device **200** may support the PCB **234**, for example, in any number of ways.

For example, the PCB **234** may be attached to the housing **222** in any number of ways including, for example, with one or more fasteners (e.g., screws or nut/bolt combinations), welds, adhesive, tabs, flanges, other devices, or any combination thereof.

**[0108]** The housing **222** of the sensor device **200** may be made of any number of materials. For example, the housing **222** of the sensor device **200** may be made of a same material (e.g., a composite material) as the rim **122**. In another example, the housing **222** of the sensor device **200** is made of two or more material. For example, the cover **230** of the housing **222** is made of a same material (e.g., a composite material) as the rim **122**, and a remainder of the housing **222** is made of another material (e.g., a plastic). In yet another example, the housing **222** of the sensor device **200** is made of a different material (e.g., a plastic) than the rim (e.g., a composite material).

**[0109]** The housing **222** of the sensor device **200** may be any number of sizes and/or shapes. The size and/or shape of the housing **222** may be defined by a size and a shape of the volume **220** within the rim **122**, spoke spacing for a wheel on which the rim **122** is installed, and/or a number and size of components supported within the housing **222**. For example, a size of a power source (e.g., a coin cell battery) supported within the housing **222** may define a minimum size of the housing **222** of the sensor device **200**.

**[0110]** The battery housing **224** may be configured in any number of ways, and the housing **222** of the sensor device **200** may support the battery housing **224** in any number of ways. For example, referring to FIGS. 7-13, the battery housing **224** may be a tray that is insertable into a corresponding opening **236** within the housing **222**. For example, the opening **236** may extend through the cover **230** of the housing **222** and into the housing **222**.

**[0111]** Referring to FIGS. 7, 11, and 12, the tray **224**, for example, supports a battery **238** (e.g., a coin cell battery). The tray **224** may be any number of shapes and/or sizes. The tray **224** may be smaller than the housing **222** of the sensor device **200** and may be, for example, rectangular in shape. The tray **224** may be sized and/or shaped, such that the battery **238** fits within the tray **224**. For example, a size of the battery **238** (e.g., a coin cell battery) supported within the tray **224** may define a minimum size of the tray **224**. Other configurations may be provided.

**[0112]** The tray **224** may be made of any number of materials. For example, the tray **224** may be made of a same material (e.g., a composite material) as the rim **122** and/or the housing **222** of the sensor device **200**. In another example, the tray **224** is made of two or more material. For example, a first portion of the tray **224** is made of a same material (e.g., a composite material) as the rim **122**, and a remainder of the tray **224** is made of another material (e.g., a plastic). In yet another example, the tray **224** is made of a different material (e.g., a plastic) than the rim (e.g., a composite material) and/or the housing **222** of the sensor device **200**.

**[0113]** Referring to FIGS. 10-12, the tray **224**, for example, may include a locking mechanism **240** that attaches (e.g., locks) the tray **224** to the housing **222** of the sensor device **200** when the tray **224** is inserted into the opening **236** through the cover **230** of the housing **222**, for example. In one embodiment, the locking mechanism **240** is

a spring loaded latch mechanism (e.g., a detent latching mechanism). In other embodiments, other locking mechanisms may be used.

[0114] In an example, the locking mechanism 240 is used for locking and unlocking the tray 224 within the housing 222. The locking mechanism 240 includes pieces that are moveable and/or rotatable relative to the housing 222 of the sensor device 200 as the tray 224 translates in and out of the opening. The locking mechanism 240 consists of a detent or protrusion 241 on the housing 222, a notch 243 on the battery tray 224, a latch 245, and an ejection mechanism 246. The detent or protrusion 241 extends away from the surface of the housing 222. The notch 243 may be an interference depression tang on the tray 224. The latch 245 may be a rotating ejection lever. The ejection mechanism 246 may be an activating pin. When the battery tray 224 is fully inserted into the housing 222, the protrusion 241 from the housing 222 nests into the notch or depression 243 on the battery tray 224 keeping the battery tray 224 in place. During insertion of the battery tray 224 into the housing 222, the latch or ejection lever 245 is rotated by the battery tray 224. This rotation of the ejection lever 245 also pushes the ejection mechanism or pin 246 towards the opening 252. FIG. 11 shows the locking mechanism 240 in the locked configuration.

[0115] To unlock the locking mechanism 240 and remove the battery tray 224, a pin 246 may be acted upon using a tool inserted through the opening 252 in the battery tray 224. When the pin 246 is depressed by a tool through the opening 252, the pin 246 rotates the ejection lever 245. This rotation of the ejection lever 245 creates a force on the battery tray 224. The force on the battery tray 224 pushes the battery tray 224 out of the housing 222.

[0116] The sensor device 200 includes electrical terminals that come into contact with the battery 238 within the tray 224 as the tray 224 moves into the locked position (e.g., as shown in FIG. 11). The electrical terminals may also be electrically connected to electronic components of the sensor device 200, such that the battery 238 powers the electronic components of the sensor device 200 when the tray 224 is in the locked position (e.g., as shown in FIG. 11). For example, the electrical terminals may be electrically connected to the PCB 234, such that the battery 238 powers any electrical components electrically connected to the PCB 234. In one embodiment, when the tray 224 is in the locked position, the battery 238 powers a pressure sensor 244 of the sensor device 200.

[0117] The housing 222 of the sensor device 200 houses an ejection mechanism that may be actuated by a user to unlock the tray 224 and move the tray 224 relative to the housing 222. In one embodiment, the ejection mechanism is a captive pin 246 in contact with the ejection lever 245 of the locking mechanism 240 when the tray 224 is in the locked position. The ejection mechanism may not be actuable without a tool. For example, when the tray 224 is in the locked position, all of the ejection pin 246 may be disposed within the housing 222 of the sensor device 200.

[0118] FIG. 12 shows the tray 224 in an unlocked position relative to the housing 222 of the sensor device 200, with the tray 224 being able to move (e.g., translate) relative to the housing 222. As shown in FIG. 12, the ejection pin 246 is in a retracted position (e.g., has been actuated by a tool) and is in contact with the ejection lever 245. Movement of the ejection pin 246 into the retracted position combined (e.g.,

towards the inner surface 242 of the housing 222 of the sensor device 200) combined with the contact between the ejection pin 246 and the ejection lever 245 causes the ejection lever 245 to rotate (e.g., in a clockwise direction) relative to the housing 222 of the sensor device 200. The ejection lever 245 is shaped (e.g., V-shaped) such that the rotation of the ejection lever 245 (e.g., in the clockwise direction) relative to the housing 222 of the sensor device 200 puts a portion 249 of the ejection lever 245 into contact with the tray 224 and/or the battery 238 and pushes the detent 241 of the housing 222 out of the notch 243 within the tray 224. The tray 224 is then in the unlocked position relative to the housing 222 of the sensor device 200, and the tray 224 is free to move (e.g., translate) relative to the housing 222.

[0119] Referring to FIGS. 5, 7, and 11, the tray 224 may include a cover 248 that forms part of the radially inner portion 136 of the rim 122 when the tray 224 is installed in the housing 222 of the sensor device 200 (e.g., in the locked position, as shown in FIG. 11). At least one dimension (e.g., a length) of the cover 248 may be larger than same dimension(s) of the tray 224, such that a tab 250 is formed. The tab 250 may include an opening 252a through the tab 250 (e.g., a through-hole). The opening 252a through the tab 250 may align with the ejection pin 246 when the tray 224 is in the locked position. A user may insert a tool through the opening 252a to interact with (e.g., press) the ejection pin 246 and unlock the tray 224, such that the tray 224 may be moved (e.g., translated) relative to and/or out of the housing 222 of the sensor device 200.

[0120] In the orientation shown in FIG. 11, when the ejection pin 246 is pressed with the tool, the locking mechanism 240 rotates in a clockwise direction and, due to contact between the locking mechanism 240 and the inner surface 242 of the housing 222, pushes the tray 224 out of the locked position. This motion pushes the detent 241 of the housing 222 of the sensor device 200 out of the notch 243 of the tray 224, for example.

[0121] The tray 224 may also act as a water-tight sealing mechanism for the sensor device 200. Referring to FIGS. 9 and 11, the tray 224 may include one or more seals 254 (e.g., a seal 254) to prevent moisture ingress when the tray 224 is installed within the housing 222 of the sensor device 200 and in the locked position. The seal 254 may be any number of different types of seals including, for example, a gasket or an O-ring configured to create a water-tight seal when the tray 224 is installed within the housing 222 of the sensor device 200 and in the locked position.

[0122] The seal 254 may be in any number of positions on the tray 224. For example, as shown in the example of FIGS. 9 and 11, the seal 254 may be at or adjacent to the cover 248 of the tray 224. In other embodiments, the seal 254 and/or other seals are disposed in other locations to provide the water-tight seal. For example, in one embodiment, the tray 224 does not include a seal, but the housing 222 of the sensor device 200 includes a seal (e.g., a gasket) at or adjacent to and around the opening 236 in the cover 230 of the housing 222. In an embodiment, the ejection mechanism or pin 246 also includes a seal, such as an O-ring or gasket.

[0123] In other embodiments, the tray 224 is attached (e.g., locked) to the housing 222 of the sensor device 200 in other ways. For example, referring to FIG. 14, instead of using the locking mechanism 240 to attach the tray 224 to the housing 222 of the sensor device 200, an opening 252b

through the tab **250** of the tray **224** may be larger (e.g., have a larger diameter), and the housing **222** may have a threaded opening that aligns with the opening **252b** through the tab **250** when the tray **224** is installed within the housing **222**. The tray **224** may be attached (e.g., locked) to the housing **222** of the sensor device **200** with a fastener **256** (e.g., a screw or a bolt) via the opening **252b** through the tab **250** of the tray **224** and the threaded opening in the housing **222**.

[0124] The tray **224**, for example, facilitates installation and removal of the battery **238** from the sensor device **200** at the radially inner portion **136** of the rim **122**. Electronic devices attached to an external surface of a wheel (e.g., the wheel **54** or **56**) of a bicycle (e.g., the bicycle **50**), for example, are easily accessible to remove and replace batteries. Electronic devices installed within a body of the bicycle, however, are more difficult to access for battery installation and removal. Integrating the tray **224** with an outer surface of the housing **222** of the sensor device **200** (e.g., the cover **230** of the housing **222**) that is accessible at the radially inner portion **136** of the rim **122** avoids having to uninstall the sensor device **200** from the rim **122** when installing or removing the battery. This integration also avoids having to depressurize a tire (e.g., the tire **120**) installed on the rim **122** and/or removal of the tire to gain access to the battery, which is a cumbersome and time consuming process.

[0125] Referring to FIGS. 3, 6, 7, and 10-14, the sensor device **200** (e.g., the housing **222** of the sensor device **200**) may be attached (e.g., mounted or anchored) to the rim **122** with a fastener **260**. The sensor device **200** may, for example, be attached to the radially outer tire engaging portion **130** with the fastener **260**. In the embodiment shown in FIGS. 3, 6, 7, and 10-14, the sensor device **200** may be attached to the radially outer tire engaging portion **130** at the well **212** with the fastener **260**.

[0126] Referring to FIG. 11, the radially outer tire engaging portion **130** includes an opening **262** that extends through the radially outer tire engaging portion **130**. The opening **262** is, for example, within the well **212** of the radially outer tire engaging portion **130**. In one embodiment, the rim **122** has a reinforced portion **264** around the opening **262**. The reinforced portion **264** around the opening **262** through the rim **122** is, for example, a thicker composite laminate compared to other parts of rim **122**.

[0127] The fastener **260** has a head **266** and threads **268**. The fastener **260** extends through the opening **262** through the radially outer tire engaging portion **130**, such that the head **266** of the fastener **260** is in contact with (e.g., abuts) the reinforced portion **264** around the opening **262** through the radially outer tire engaging portion **130**, and the threads **268** engage with the housing **222** of the sensor device **200**. The housing **222** of the sensor device **200** may include a threaded opening **269**, and the sensor device **200** may be attached to the rim **122** via a threaded connection between the threads **268** of the fastener **260** and the threaded opening **269**.

[0128] As the fastener **260** is turned into the housing **222** of the sensor device **200** via the threaded connection, the housing **222** of the sensor device **200** is pulled towards the radially outer tire engaging portion **130**, and the flange **232** of the cover **230** of the housing **222** of the sensor device **200** is pulled into contact with the flange **228** of the receptacle **152** within the rim **122**. The fastener **260** may be tightened within the threaded opening **269** within the housing **222** of

the sensor device **200** to tighten the cover **230** of the housing **222** against the rim **122**. In one embodiment, when the flange **232** of the cover **230** is in contact with the flange **228** of the receptacle **152**, the housing **222** of the sensor device **200** is at a distance relative to (e.g., remote from) the radially outer tire engaging portion **130** of the rim **122**. In other words, when the sensor device **200** is attached to the radially outer tire engaging portion **130** of the rim **122** via the fastener **260**, the housing **222** of the sensor device **200** is not in contact with the radially outer tire engaging portion **130** of the rim **122**.

[0129] In the embodiment shown in FIGS. 3-14, the fastener **260** is a ported bolt. Referring to FIGS. 11-13, the ported bolt **260**, for example, includes a passage **270** along a length of the ported bolt **260**. When the ported bolt **260**, for example, is threaded into the threaded opening **269** within the housing **222** of the sensor device **200**, the passage **270** through the ported bolt **260** fluidly connects a port **272** of the pressure sensor **244** of the sensor device **200** to a volume **274** (e.g., a tire cavity) between the first tire retaining portion **202** and the second tire retaining portion **204** of the radially outer tire engaging portion **130** of the rim **122**. The pressure sensor **244** is thus configured to measure a pressure of a fluid (e.g., air) within the volume **274** (e.g., a tire pressure) via the passage **270** fluidly connecting the volume **274** to the pressure sensor **244**.

[0130] The ported bolt **260** includes one or more seals **276** (e.g., O-rings or gaskets) configured to provide an airtight seal along a path between the volume **274** (e.g., the tire cavity) and the sensor device **200**. For example, the ported bolt **260** includes a first seal **276a** disposed around the ported bolt **260** adjacent to the head **266** of the ported bolt **260**, and a second seal **276b** disposed around the ported bolt **260** adjacent to the threads **268** of the ported bolt **260**. The ported bolt **260** may include more, fewer, and/or different seals, and/or the first seal **276a** and/or the second seal **276b** may be provided in different positions along the ported bolt **260**, respectively. In an alternate embodiment, the second seal **276b** may be located on the housing, near the ported bolt **260** and/or in contact with the ported bolt **260**.

[0131] The ported bolt **260** may be made of any number of different materials. For example, the ported bolt **260** may be made of a metal such as, for example, alloy steel, though the ported bolt **260** may be made of other material. The ported bolt **260** may be any number of shapes and sizes. For example, the length of the ported bolt **260** may be sized such that the housing **222** of the sensor device is not in contact with the radially outer tire engaging portion **130** of the rim **122** when the sensor device **200** is attached to the radially outer tire engaging portion **130** of the rim **122** via the ported bolt **260**. As another example, a diameter of a shaft of the ported bolt **260** may be minimized while still allowing fluid communication between the port **272** of the pressure sensor **244** of the sensor device **200** and the volume **274**, such that the corresponding opening **262** through the radially outer tire engaging portion **130** is also minimized.

[0132] Referring to FIG. 11, the ported bolt **260** forms a blind pressure tap that exposes the port **272** of the pressure sensor **244** to the atmosphere within the volume **274** between the first tire retaining portion **202** and the second tire retaining portion **204** of the radially outer tire engaging portion **130** of the rim **122** (e.g., a pressurized tire cavity). The blind nature of the exposure to the pressurized tire cavity **274**, for example, helps prevent sealant contained

within a tire attached to the rim **122** or sealant added through the valve, for example, from being passed to the sensor device **200** (e.g., the pressure sensor **244** of the sensor device). This prevents clogging of the pressure sensor **244**, for example, minimizing inaccurate measurements by the pressure sensor **244**.

[0133] In an embodiment, the air passage to the pressure sensor may include a material. For example, passage **270** may be filled (fully or partially) with material. In an alternate example, passage **270** and the port **272** may be filled (fully or partially) with material. In the example, the material may be a low durometer material capable of translating pressure effectively. The material may be rubber, silicon, and/or any easily compressed material. Pre-filling the passage allows air in the tire bed to push on the soft material which translates the material to the sensor **244**. The pre-filled material will not leak or fall out of the passage, and will help to reduce the risk of the passage clogging with sealant.

[0134] A sensor device may be attached to the rim **122** and/or a sensor device (e.g., a pressure sensor of the sensor device) may be fluidly connected to the tire cavity **274**, for example, in any number of other ways. For example, referring to FIG. **15**, a fluid connection between a sensor device **600** and the tire cavity **274**, and the attachment of the sensor device **600** to the rim **122** may be separated. In other words, a ported bolt **282** may not be used to both attach the sensor device **600** to the rim **122** and fluidly connect the sensor device **600** to the tire cavity **274**.

[0135] The embodiment described in FIG. **15**, is similar to and shares many of the same elements as the second embodiment described below. Most elements are not described in relation to FIG. **15** if they are identical or similar to those found in the second embodiment below. Features and elements described in the first and second embodiments may be interchanged or combined with the features of FIG. **15**.

[0136] As seen in the embodiment of FIG. **15**, the sensor device **600** includes a cover **604** and a housing **602**. The cover **604** includes a display. In the example, the display may be an LED **606**.

[0137] For example, a ported bolt **282** may extend through an opening **284** through the radially outer tire engaging portion **130** of the rim **122** to expose a pressure sensor within the pressure sensor cavity or port **610** of the sensor device **600**, for example, to a pressure within the tire cavity **274** (e.g., a tire pressure), but not attach the sensor device **600** to the rim **122**. Such a ported bolt **282** may be attached to the rim **122** at the radially outer tire engaging portion **130** using, for example, threads **288** of the ported bolt **282** and a rivet nut **290** installed within the opening **284** through the radially outer tire engaging portion **130** of the rim **122**. The ported bolt **282** may be tightened against the rivet nut **290**, and a seal **292** (e.g., a sealing gasket) may be disposed between a head **294** of the ported bolt **282** and a surface **296** of the radially outer tire engaging portion **130** (e.g., within the well **212** of the radially outer tire engaging portion **130**). In the example, the pressure sensor cavity **610** is a volume that houses the pressure sensor. In the example, the pressure sensor cavity **610** is fluidly connected to the flexible tube **299**. In an example the pressure sensor cavity **610** is fluidly connected to the tire cavity **274** via the flexible tube **299** and ported bolt **282**. In an example, the pressure sensor cavity **610** is similar to the port **272** described below.

[0138] The ported bolt **282** may include a fluid passage **297** within and along a length of the ported bolt **282**. Each of the ported bolt **282** and the sensor device **600** may include a fixing member **298** to which a flexible tube **299** (e.g., a flexible hose), for example, is connected. The fixing members **298** may be any number of different types of fixing devices for providing a leak-proof seal with the flexible tube. For example, the fixing members **298** may include barbs, compression fittings, luer locks, quick-disconnect fittings, other fixing devices, or any combination thereof.

[0139] The sensor device **600** (e.g., the pressure sensor of the sensor device) may be fluidly connected to the tire cavity **274**, for example, via the ported bolt **282**, the fixing members **298**, and the flexible tube **299**. By using the flexible tube **299**, the sensor device **600** may be arbitrarily placed on or within the rim **122**, and may be relocated while still maintaining a pressure within the tire cavity **274**. This allows a battery of the sensor device **600**, for example, to be replaced without having to depressurize the tire and disconnect the sensor device **600**.

[0140] In a further alternate embodiment, a sensor device may use a tube within the tire to act upon the fluid and/or sense the pressure within the inside of the tire.

[0141] A second embodiment of a sensor device **300** utilizes the fixing members described above and, for example, the flexible tube, and is attached to the radially inner portion **136** of the rim **122** instead of the radially outer tire engaging portion **130** of the rim **122** (e.g., as with the sensor device **200** of the first embodiment). FIGS. **16-23** illustrate the sensor device **300**, which may be attached (e.g., mounted) to the rim **122** and fluidly connected to, for example, a volume defined by the tire engaging portion **130** of the rim **122** (e.g., the tire cavity), according to a second embodiment.

[0142] The sensor device **300** utilizes and/or acts similarly to a flip toggle bolt, such that a wider object (e.g., the sensor device **300**) may be installed through a narrower opening. This attachment mechanism allows a smaller receptacle **152** through the radially inner portion **136** of the rim **122** to be used. As openings (e.g., holes) through a structure may reduce the integrity of the structure, by using a smaller receptacle **152** (e.g., compared to the first embodiment shown in FIGS. **3-14**) through the radially inner portion **136** of the rim **122** to attach a sensor device (e.g., the sensor device **300**) to the rim **122**, reinforcement around the receptacle **152** may be minimized. For example, the composite laminate around the receptacle **152** of the second embodiment shown in FIGS. **16-23** may be thinner than the composite laminate around the receptacle **152** of the first embodiment shown in FIGS. **3-14**.

[0143] The sensor device **300** includes a housing **302** and a cover **304** (e.g., an outer plate or an external plate) physically connected to the housing **302** of the sensor device **300** with a fixing member **306**. The housing **302** supports one or more electronic components (e.g., one or more processors, a pressure sensor, a power source such as a coin cell battery, a memory) in communication with each other (e.g., via a PCB supported by the housing). The housing **302** may be made of any number of materials including, for example, a plastic or a composite material. The housing **302** may be any number of shapes and/or sizes. For example, at least one dimension (e.g., a length) of the housing **302** may be larger than at least one dimension (e.g., a length) of the cover **304**.



[0144] In one embodiment, the housing 302 of the sensor device 300 is shaped to interface with an inner surface 308 of the radially inner portion 136 of the rim 122. In other words, a portion of the housing 302 is sized and/or shaped to match a size and/or shape of the inner surface 308 of the radially inner portion 136 of the rim 122. For example, referring to FIGS. 16 and 20, the housing 302 of the sensor device 300 has at least one outer surface 310 (e.g., an outer surface 310) that is shaped (e.g., parabolic) to match the shape (e.g., parabolic) of the inner surface 308 of the radially inner portion 136 of the rim 122. The outer surface 310 of the housing 302 of the sensor device 300 may act as a pressure bearing surface when the sensor device 300 is attached to the rim 122 (e.g., the cover 304 and the housing 302 of the sensor device 300 are drawn together, such that the sensor device 300 is clamped to the rim 122).

[0145] The cover 304 forms part of the radially inner portion 136 of the rim 122 when the sensor device 300 is attached to the rim 122. The cover 304 may be any number of shapes and sizes. For example, the cover 304 may be sized and shaped to match a size and shape of the receptacle 152 through the radially inner portion 136 of the rim 122. Other shapes and/or sizes may be provided.

[0146] The cover 304 of the sensor device 300 may be made of any number of materials. For example, the cover 304 of the sensor device 300 may be made of a same material (e.g., a composite material) as the rim 122. In another example, the cover 304 of the sensor device 300 is made of a different material (e.g., a plastic) than the rim 122 (e.g., a composite material).

[0147] In one embodiment, the fixing member 306 is a bolt (e.g., part of a flip toggle bolt or similar in function to a flip toggle bolt, made up of housing 300, support 316, and bolt 306). The bolt 306 may, for example, be captive within the cover 304, and may include a shaft 312 having threads 314. The cover 304 may be pivotable relative to the shaft 312. Other fixing members 306 may be provided.

[0148] Referring to FIGS. 19 and 22, the sensor device 300 may include a support 316 that is rotatably attached to the housing 302 of the sensor device 300. In one embodiment, the support 316 is a body (e.g., a cylindrically shaped body) that is captive within a channel 318 within the housing 302 of the sensor device 300. The channel 318 is defined by walls 320 within the housing 302. The support 316 may include a threaded through-hole to which the cover 304 is attachable via the bolt 306. When the bolt 306 is attached to the support 316 via the threaded hole through the support 316, for example, the walls 320 of the channel 318 define an extent of an angular rotation (e.g., 30 degrees), through which the support 316, the bolt 306, and the cover 304 may move relative to the housing 302 of the sensor device 300. With this configuration, the cover 304 and the housing 302 of the sensor device 300 may be independently pivotable relative to the bolt 306, while maintaining a mechanical connection with the bolt 306, for example. In other words, the cover 304 and the housing 302 (e.g., the outer surface 310 of the housing 302) may be pivotable relative to each other while maintaining a mechanical connection to each other.

[0149] The independent pivotability of the cover 304 and the housing 302 of the sensor device 300 relative to the bolt 306 allows a housing 302 of a sensor device 300 larger than the receptacle 152 to be positioned within and attached to the rim 122. For example, with the cover 304 in an extended

position relative to the housing 302 of the sensor device 300 (see FIGS. 16-19), the cover 304 may be pivoted in a first rotational direction (e.g., clockwise) relative to the housing 302 of the sensor device 300 (e.g., until the cover 304 contacts the housing 302 of the sensor device 300). A portion of the housing 302 of the sensor device 300 may then be positioned into the receptacle 152 and under the radially inner portion 136 of the rim 122. The housing 302 of the sensor device 300 may then be rotated in the first rotational direction (e.g., clockwise) relative to the cover 304 (e.g., with the cover 304 being rotated in a second rotational direction, such as counter-clockwise, relative to the housing 302 of the sensor device 300). The cover 304 and the housing 302 of the sensor device 300 may then be centered within the receptacle 152. Once centered, the cover 304 may contact the flange 228 of the receptacle 152 (see FIG. 17). With the cover 304 in contact with the flange 228 of the receptacle 152 and/or the outer surface 310 of the housing 302 in contact with the inner surface 308 of the radially inner portion 136 of the rim 122, the cover 304 and/or the housing 302 may not be able to rotate relative to the rim 122 due to friction. The bolt 306 may then be rotated relative to the cover 304 and/or the housing 302 of the sensor device 300, which causes the cover 304 and the outer surface 310 of the housing 302 of the sensor device 300 to come together and clamp the rim 122. The bolt 306 may be tightened, and the sensor device 300 may be attached (e.g., mounted or anchored) to the rim 122 (see FIGS. 20-22).

[0150] With such a configuration, the sensor device 300 may be removed from the rim 122 when a power source for the sensor device (e.g., a battery) is to be installed, removed, or replaced. In other words, the battery may not be accessible at the radially inner portion 136 of the rim 122 without removing the housing 302 of the sensor device 300 from within the rim.

[0151] Referring to FIGS. 19 and 22, the sensor device 300 may also include a battery housing 322. The battery housing 322 may be integral with the housing 302, and a battery disposed within the battery housing 322 may be retained within the battery housing 322 with a battery cover 324. The battery cover 324 may be attached to the battery housing 322 in any number of ways to retain the battery within the battery housing 322. For example, the battery cover 324 may include one or more attachment features 326 such as, for example, tabs, flanges, openings, fasteners, other attachment features, or any combination thereof. The battery housing 322 may include one or more attachment features 328 that correspond to the one or more attachment features 326 of the battery cover 324, such as, for example, tabs, flanges, openings, fasteners, other attachment features, or any combination thereof.

[0152] Referring to FIG. 23, as in the previous embodiments, the housing 302 of the sensor device 300 may support a PCB 332, and the PCB 332 and/or the housing 302 may support any number of electronic components including, for example, a pressure sensor 334. The pressure sensor 334 may be electrically connected to any number of other electronic components of the sensor device 300 (e.g., a processor) via the PCB and/or other electrical connections.

[0153] Referring to FIGS. 18-23, the housing 302 may also support a fixing member 330 that extends away from a surface of the housing 302 and fluidly connects an exterior of the housing 302 to an interior of the housing 302. For example, the pressure sensor of the sensor device 300 may

be fluidly connected to the volume 274 within the radially outer tire engaging portion 130 of the rim 122 (e.g., a pressurized tire cavity) via the fixing member 330 and a flexible tube physically connected to the fixing member 330 and the radially outer tire engaging portion 130 of the rim 122 (e.g., via a ported bolt, as discussed above).

[0154] The fixing member 330 may be any number of different types of fixing devices. For example, in the embodiment shown in FIGS. 16-23, the fixing member 330 is a hollow barb, to which the flexible tube is attached. Other types of fixing members may be provided.

[0155] Referring to FIG. 23, a fluid passage 336 (e.g., at least partially forming a fluid path) extends through the fixing member 330 and a portion 338 of the housing 302. The fluid passage 336 fluidly connects an exterior of the sensor device 300 (e.g., the tire cavity 274 via a flexible tube physically connected to the fixing member 330) to, for example, the pressure sensor 334 supported by and electrically connected to the PCB 332.

[0156] FIGS. 24-31 illustrate a sensor device 400 that may be attached (e.g., mounted) to the rim 122 and fluidly connected to, for example, a volume defined by the tire engaging portion 130 of the rim 122 (e.g., the tire cavity), according to a third embodiment. Similar to the first embodiment of the sensor device 200 shown in FIGS. 3-14, the sensor device 400 may be attached to the radially outer tire engaging portion 130 of the rim 122. In other embodiments, the sensor device 400 may be attached to the radially inner portion 136 of the rim 122 and/or attached to the radially outer tire engaging portion 130 of the rim 122 in another way.

[0157] Referring to FIGS. 29 and 31, similar to the first embodiment of the sensor device 200 shown in FIGS. 3-14, the sensor device 400 includes a housing 402 that is attached between the radially inner portion and outer tire engaging portions. For example, the sensor device 400 is clamped between the radially inner portion and outer tire engaging portion with a connector 404. The sensor device 400 includes a battery housing 406 removably attached to the housing 402, such that the battery housing 406, and thus a battery 408 disposed within the battery housing 406, is accessible at the radially inner portion 136 without removing the housing 402 from the rim 122. For example, the battery housing 406 is configured as a tray, and the tray 406 is slidable relative to the housing 402 of the sensor device 400 and lockable relative to the housing 402 via a locking mechanism 410.

[0158] Referring to FIG. 29, the sensor device 400 includes a pressure sensor 412 that is powered by the battery 408 disposed within the battery housing 406. The sensor device 400 is attached to the rim 122 with a connector 404, such that an outer surface of the sensor device 400 (e.g., including an outer surface 416 of the housing 402 and an outer surface 418 of the battery housing 406 of the sensor device 400) is flush with the radially inner portion 136 of the rim 122. In other words, the sensor device 400 is attached to the rim 122, such that the outer surface of the sensor device 400 forms part of the radially inner portion 136 of the rim 122.

[0159] In the third embodiment shown in FIGS. 24-31, the sensor device 400 is attached to the radially outer tire engaging portion 130 of the rim 122. Referring to FIGS. 28, 30, and 31, the rim 122 includes an opening 420 (e.g., a reinforced opening) through the radially outer tire engaging

portion 130 of the rim 122, at the well 212 of the radially outer tire engaging portion 130. Part of the connector 404 extends through the opening 420 and connects the housing 402 of the sensor device 400 to the radially outer tire engaging portion 130 of the rim 122.

[0160] In the embodiment shown in FIGS. 24-31, the connector 404 includes a container 422 (e.g., a pouch) disposed within the volume 274 within the radially outer tire engaging portion 130 of the rim 122 (e.g., at least partially within the well 212 of the radially outer tire engaging portion 130), and a shaft 424 physically and fluidly connected to the container 422. The shaft 424 is, for example, a tube (e.g., a flexible tube), though other configurations may be provided. The shaft 424 includes threads 426 on an outer surface of the shaft 424. The threads 426 are connectable to corresponding threads 428 within a threaded opening 430 in the housing 402 of the sensor device 400 to attach the connector 404 to the housing 402 of the sensor device 400, and thus the sensor device 400 to the rim 122.

[0161] Rotating the connector 404 relative to the housing 402 of the sensor device 400 in a tightening direction (e.g., a first rotational direction) while the threads 426 of the shaft 424 are engaged with the corresponding threads 428 within the threaded opening 430 in the housing 402 causes the housing 402 of the sensor device 400 to translate towards the radially outer tire engaging portion 130 of the rim 122 until the sensor device 400 (e.g., the housing 402 of the sensor device 400) is seated within the receptacle 152 through the radially inner portion 136 of the rim 122.

[0162] Referring to FIGS. 29 and 31, the tube 424, for example, includes a passage 432 extending along a length of the tube 424. The passage 432 is fluidly connected to an interior volume 434 of the container 422. The interior volume 434 of the container 422 is at least partially filled with a fluid 436. In one embodiment, the fluid 436 is an incompressible fluid (e.g., a hydraulic oil). In other embodiments, the fluid 436 is compressible.

[0163] The container 422 may be flexible (e.g., made of rubber, polyvinyl chloride (PVC), or low density polyethylene (LDPE)). The container 422 at least partially filled with the fluid 436 is exposed to a pressure (e.g., a tire pressure) within the volume 274 within the radially outer tire engaging portion 130 of the rim 122 (e.g., the tire cavity) and transmits the pressure to the pressure sensor 412 via the passage 432 (e.g., a fluid path) extending along the length of the tube 424 (e.g., when the threads 426 of the connector 404 are connected to the corresponding threads 428 within the threaded opening 430 in the housing 402 of the sensor device 400).

[0164] The container 422 being made of a flexible material allows pressure from a surrounding atmosphere (e.g., tire pressure) to be transferred to the fluid 436 contained within the container 422 (e.g., the pressure from the surrounding atmosphere corresponds to a pressure of the fluid 436 contained within the container 422). A volume of the fluid 436 within the container 422 is to be large enough to transmit the tire pressure, for example, without running out of fluid to transmit pressure. An appropriate volume depends on a compressibility of the system (e.g., fluid compressibility, residual air bubbles, and flex of the container 422). An incompressible system will transfer pressure forces to the pressure sensor 412 without changing a volume of the container 422, while a compressible system transfers the fluid 436 towards the pressure sensor 412 to equalize a

pressure in the system. The fluid **436** may be selected to have temperature stability (e.g., freeze point, boiling point) and chemical compatibility with any containment elements (e.g., the container **422** and the tube **424**).

[0165] The tube **424** transmitting the pressure between the container **422** of the connector **404** and the pressure sensor **412** may be any number of lengths, which allows for optimal placement of the sensor device **400** and/or the container **422** to best suit design requirements of a wheel and/or the rim **122**. This configuration (e.g., including the container **422** and the tube **424** filled with the fluid **436**) makes the sensor device **400** compatible with both tubed or tubeless wheel setups, and creates a closed pressure sensing circuit that cannot be fouled by tire sealant.

[0166] FIG. **32** shows one embodiment of a wheel assembly **500** for a bicycle (e.g., the bicycle **50**) that includes a sensor device **502** and a wheel **503** (e.g., wheel **54** or **56**). The sensor device **502** may be the first embodiment of the sensor device **200** of FIGS. **3-14**, the second embodiment of the sensor device **300** of FIGS. **16-23**, the third embodiment of the sensor device **400** of FIGS. **24-31**, or another sensor device. The sensor device **502** includes a housing **504** that supports a PCB **506**, one or more electronic components, and one or more power sources **508** (e.g., a coin cell battery). As discussed above, the coin cell battery **508**, for example, may be supported by a battery housing (e.g., a tray), and the battery housing may be supported by the housing **504** (e.g., removably attached to the housing **504**). The one or more power sources **508** may power any number of the one or more electronic components of the sensor device **502**. Other configurations of the battery housing may be provided.

[0167] The one or more electronic components may include electronic components supported and electrically connected by the PCB **506**, and electronic components supported by the housing **504** and, for example, electrically connected to the electronic components of the PCB **506** via one or more conductors (e.g., wires and soldering). The one or more electronic components may include any number of different types of electronic components including, for example, one or more processors **510** (e.g., a microcontroller), a user interface module **512** (e.g., a light emitting diode (LED)), a radio **514** (e.g., an antenna), one or more sensors including, for example, a pressure sensor **516**, an accelerometer **518**, and a magnetometer **520**, a radio-frequency identification (RFID) reader **522**, and a resistance measurement interface **523**. The one or more electronic components may include more, fewer, and/or different electronic components. For example, the one or more electronic components may include additional sensors including, for example, a wheel speed sensor. As another example, the one or more electronic components may include a memory.

[0168] The one or more processors **510** (e.g., a processor) may include a general processor, digital signal processor, an application specific integrated circuit (ASIC), field programmable gate array (FPGA), analog circuit, digital circuit, combinations thereof, or other now known or later developed processor. The processor **510** may be a single device or combinations of devices, such as through shared or parallel processing.

[0169] The memory, for example, may be a volatile memory or a non-volatile memory. The memory may include one or more of a ROM, a RAM, a flash memory, an EEPROM, or other type of memory. The memory may be removable from the sensor device **502**, such as an SD

memory card. In a particular non-limiting, exemplary embodiment, a computer-readable medium may include a solid-state memory such as a memory card or other package that houses one or more non-volatile read-only memories. Further, the computer-readable medium may be a random access memory or other volatile re-writable memory. Additionally, the computer-readable medium may include a magneto-optical or optical medium, such as a disk or tapes or other storage device. Accordingly, the disclosure is considered to include any one or more of a computer-readable medium and other equivalents and successor media, in which data or instructions may be stored.

[0170] The memory is a non-transitory computer-readable medium and is described to be a single medium. However, the term “computer-readable medium” includes a single medium or multiple media, such as a centralized or distributed memory structure, and/or associated caches that are operable to store one or more sets of instructions and other data. The term “computer-readable medium” shall also include any medium that is capable of storing, encoding, or carrying a set of instructions for execution by a processor or that cause a computer system to perform any one or more of the methods or operations disclosed herein.

[0171] The one or more power sources **508** include a portable power source that may be stored internal to the sensor device **502** or stored external to the sensor device **502** and communicated to the sensor device **502** through a power conductive cable. The one or more power sources **508** may involve the generation of electric power, for example, using a mechanical power generator, a fuel cell device, photovoltaic cells, piezoelectric, or other power-generating devices. The one or more power sources **508** may include a battery (e.g., the coin cell battery) such as a device consisting of two or more electrochemical cells that convert stored chemical energy into electrical energy. The one or more power sources **508** may include a combination of multiple batteries or other power providing devices. Specially fitted or configured battery types, or standard battery types may be used.

[0172] The user interface module **512** may be a user interface that communicates information to a rider. For example, the user interface module **512** may be a multicolor LED **512** configured to communicate a status of at least one sensor (e.g., the pressure sensor **516**) of the one or more sensors of the sensor device **502**. The LED **512** may, for example, be controlled by the processor and may be visible to the rider at a radially inner portion of a rim (e.g., rim **524** or the rim **122**) to which the sensor device **502** is attached. The LED **512** may be part of a larger user interface that includes one or more additional displays including, for example, an LCD panel, an LED screen, a TFT screen, or another type of display. Such a user interface may also include audio capabilities or speakers. In other embodiments, the user interface may also include one or more buttons, a rocker switch, a touch pad, a voice recognition circuit, or another device or component for communicating data between a user and the sensor device **502**. The user interface may also include a touch screen that may be capacitive or resistive. The user interface may include additional, fewer, and/or different components.

[0173] The radio **514** (e.g., the antenna) is a communication device configured to transmit and receive (e.g., with a communication interface) data such as measurement data (e.g., tire pressure data, wheel speed data, wheel odometer

data, wheel lean and yaw data, product data, road feedback data), rim composite health signals, status signals (e.g., charge status for the one or more power sources **508**), LED status indicators, operation signals, and/or other signals.

[0174] The radio **514** provides for data and/or signal communication from the sensor device **502** to another component of the bicycle, or an external device such as a mobile phone or other computing device. The radio **514** communicates the data using any operable connection. An operable connection may be one in which signals, physical communications, and/or logical communications may be sent and/or received. An operable connection may include a physical interface, an electrical interface, and/or a data interface. The radio **514** may be configured to communicate wirelessly, and as such include one or more antennae. The radio **514** provides for wireless communications in any now known or later developed format.

[0175] In one embodiment, the sensor device **502** includes more than one communication device (e.g., a plurality of antennas **514**) in communication with more than one communication interface, respectively. The communication interfaces communicate the data using any operable connection. At least one of the communication interfaces may provide for wireless communications through an antenna of the plurality of antennas **514** in any now known or later developed format. The wireless communications may be communicated using any technique, protocol, or standard. For example, Institute of Electrical and Electronics Engineers (“IEEE”) 802.11 standards, IEEE 802.15.1 or BLUETOOTH® standards, and/or ANT™ or ANT+™ standards may be used. In some embodiments, however, wireless communications may be communicated over a proprietary protocol, such as one that operates on top of the physical layer of the IEEE 802.15.4 wireless protocol. Although the present specification describes components and functions that may be implemented in particular embodiments with reference to particular standards and protocols, the invention is not limited to such standards and protocols. For example, standards for Internet and other packet switched network transmission (e.g., TCP/IP, UDP/IP, HTML, HTTP, HTTPS) represent examples of the state of the art. Such standards are periodically superseded by faster or more efficient equivalents having essentially the same functions. Accordingly, replacement standards and protocols having the same or similar functions as those disclosed herein are considered equivalents thereof.

[0176] The pressure sensor **516** may be any number of different types of pressure sensors. For example, the pressure sensor **516** may be a capacitive sensor, a piezoelectric sensor, an optical sensor, a MEMS sensor, a resistive sensor, an aneroid barometer sensor, a manometer sensor, a vacuum pressure sensor, a sealed pressure sensor, or another type of sensor.

[0177] The accelerometer **518** may be any number of different types of accelerometers. In one embodiment, the accelerometer **518** is a microelectromechanical system (MEMS) accelerometer (e.g., having three sense axes orthogonal to each other), though other types of accelerometers may be used. The accelerometer **518** may be supported within the housing **504** of the sensor device **502** (e.g., on the PCB **506** of the sensor device **502**), such that the accelerometer **518** is offset relative to a radius from a center of an

axis of rotation of the wheel **503** on which the sensor device **502** is installed (e.g., according to axis angle offset positioning).

[0178] The accelerometer **518** (e.g., a MEMS accelerometer) may have a predefined range of accelerations that the accelerometer **518** may detect. Outside of the predefined range, the accelerometer **518** may become saturated and may not provide accurate data. Centripetal force generated by a wheel (e.g., the wheel **503**) spinning may be used to back-calculate ground speed if a radial distance of an accelerometer relative to the center of the axis of rotation of the wheel (e.g., the wheel **503**), and a diameter of a tire attached to the wheel are known. Centripetal forces generated at, for example, a rim of the wheel may saturate an accelerometer positioned such that one of the three axes of sensing is oriented radially towards the center of the axis of rotation at typical riding speeds. For example, a MEMS accelerometer with a +/-16 g range may become saturated at riding speeds above 7 m/s.

[0179] The accelerometer **518** with axis angle offset positioning attenuates a value of the accelerometer **518** in the radial direction. This attenuation may be defined by the equation of  $Y=X \cos(a)$ , where  $X$  is a radial acceleration,  $Y$  is an attenuated measurement in the offset axis, and  $a$  is an axis offset angle from radial. The axis angle offset allows the MEMS accelerometer **518** to measure wheel speeds a number of times faster than a radially oriented accelerometer, as is typical in the prior art.

[0180] A tradeoff of the axis angle offset positioning of the accelerometer **518** is a reduction in sensor sensitivity at low speeds. Because centripetal force increases by a square of velocity, there may be a speed above which a reduction in sensitivity may be outrun by an increase in centripetal force sensitivity per unit of speed increase.

[0181] Absolute acceleration readings (e.g., from the accelerometer **518**) may not provide most accurate wheel speed measurements, as the accuracy depends on careful measurement of the radial distance of the accelerometer **518** to the axis of rotation, which may vary between different wheel models and different wheels of a same wheel model. With axis angle offset positioning of the accelerometer **518**, the axis offset angle from radial  $a$  is also to be accurately known.

[0182] In one embodiment, the processor **510** may determine wheel speed of the wheel (e.g., the wheel **503**) using data from the accelerometer **518** and earth’s acceleration due to gravity. The processor **510** may determine, based on the data from the accelerometer **518**, when orientation of the accelerometer **518** changes from up to down (e.g., a cycle time). The processor **510** may determine the wheel speed of the wheel based on the determined cycle time and the diameter of a tire attached to the wheel. This would avoid the need for an accurate measurement of the radial distance of the sensor to the axis of rotation, and the axis offset angle from radial  $a$ .

[0183] In one embodiment, for such a determination of wheel speed based on the determined cycle time, a data collection frequency of the accelerometer **518** may be at least four times a wheel rotation frequency (e.g., at least four times a maximum wheel rotation frequency), and a sensitivity of the accelerometer **518** may detect changes in acceleration better than 1/200 parts.

[0184] The magnetometer **520** may be any number of different types of magnetometers **520**. In one embodiment,

the magnetometer **520** is a MEMS magnetometer (e.g., having three sense axes orthogonal to each other), though other types of magnetometers may be used. The magnetometer **520** may be supported within the housing **504** of the sensor device **502** (e.g., on the PCB **506** of the sensor device **502**), such that two of the three sense axes (e.g., the X and Y axes) are in a same plane as the wheel (e.g., the wheel **503**), and one of the sense axes (e.g., the Z axis) is orthogonal to the diameter of the wheel.

[0185] The background magnetic field of earth is present everywhere on earth at between 0.25 and 0.65 Gauss. This background magnetic field may be sensed by the magnetometer **520** at a high frequency. In one embodiment, the processor **510** samples the magnetometer **520**, and thus the background magnetic field of earth, at a rate of, for example, two times a previously measured wheel speed and/or frequency of rotation. In other embodiments, the processor **510** samples the magnetometer **520**, and thus the background magnetic field of earth, at a greater or lesser rate. For example, the processor **510** may sample the magnetometer **520**, and thus the background magnetic field of earth, at a lesser rate when the wheel speed is lower (e.g., less than 4 m/s). The lesser sampling rate may increase battery life of the battery **508**.

[0186] As the wheel (e.g., the wheel **503**) rotates, a polarity of a sensed value of the background magnetic field of earth, as sensed by the magnetometer **520**, changes between positive and negative (e.g., polarity flips). For example, the sensed value is positive for one half of a rotation and negative for the other half of the rotation. The processor **510** may identify and count the polarity flips over time, and calculate wheel speed of the wheel (e.g., the wheel **503**) based on the identified polarity flips over time (e.g., a time period between two polarity flips adjacent in time) and the diameter of the tire attached to the wheel.

[0187] FIGS. 33a-33c are plots of magnetometer output for each of the three sense axes over time. Plot **700** illustrates the x-axis, plot **800** illustrates the y-axis, and plot **900** illustrates the z-axis. The plots illustrate polarity flips as the wheel (e.g., the wheel **503**) rotates. The polarity flips get closer together as the wheel speed of the wheel (e.g., the wheel **503**) increases. Portion **702**, **802**, and **902** of the plots show an area of increased wheel speed. The polarity flips get further apart as the wheel speed of the wheel decreases. Portion **704**, **804**, and **904** of the plots show where the wheel speed was slower. In an alternate embodiment, wheel speed may be determined by calculating and using the instantaneous rate of rotation and magnetometer measurements. This alternate embodiment may allow for quicker calculation of a speed value and allow the sensor to go to sleep faster, conserving battery life.

[0188] The memory of the sensor device, for example, may store a number of most recently calculated wheel speeds of the wheel. For example, the memory may store 2, 5, 10, 20, 50, or 100 of the most recently calculated wheel speeds of the wheel. An oldest wheel speed may be overwritten with each new calculation.

[0189] In one embodiment, the sampling rate is based on the most recently calculated wheel speed of the wheel. For example, sampling rate may be two times faster than the most recently calculated wheel speed of the wheel (e.g., in rotations per second). In other embodiments, the sampling

rate may be three times, four times, or another multiplier faster than the most recently calculated wheel speed of the wheel.

[0190] In one embodiment, the processor **510** may use data generated by the magnetometer **520** to wake up the sensor device **502**. For example, instead of data from the accelerometer **518** representing motion of the wheel, and thus the bicycle to which the wheel is attached, the processor **510** may identify a change in magnetic field strength in response to rotation of the wheel, and the processor **510** may wake up other components of the sensor device **502** based on the identified change in magnetic field strength.

[0191] The RFID reader **522** may take any number of forms. For example, the RFID reader **522** may be a near field communication (NFC) module. The RFID reader **522** may be in communication with an RFID chip associated with (e.g., embedded within) a rim to which the sensor device **502** is attached (e.g., the rim **524** discussed below). For example, the RFID reader **522** may be configured to receive identification information from the RFID chip associated with the rim to which the sensor device **502** is attached. The processor **510**, for example, may be configured to identify the rim based on the identification information received from the RFID chip. Identification of the rim may be provided in other ways.

[0192] The resistance measurement interface **523** may take any number of forms. For example, the resistance measurement interface **523** may be an interface of a physical and electrical connection of a sensing element (e.g., an insulated electrically conductive wire) to a conductor on the PCB **506**. The sensing element may be embedded within a rim to which the sensor device **502** is attached (e.g., the rim **524** discussed below), and may be configured to relay a change in electrical characteristics (for example, resistance, electrical continuity, and/or voltage) within the rim to the processor **510**, for example, via the PCB **506**. The processor **510**, for example, may be in communication with the resistance measurement interface **523** via, for example, the PCB **506** (e.g., tracks of the PCB **506**), and may identify a change in resistance within the rim via the sensing element.

[0193] In one embodiment, the resistance measurement interface **523** is the radio **514**, and the sensing element includes an antenna, via which the sensing element may wirelessly transmit a signal to the processor **510** via the radio **514** and the PCB **506** of the sensor device **502**. Such a transmitted signal may include data for a current applied to the sensing device, a measured voltage drop across the sensing device, or a combination thereof.

[0194] The wheel **503** includes a rim **524** (e.g., the rim **122**). The rim **524** may include one or more components to which the sensor device **502** and/or one or more components of the sensor device **502** are physically, electrically, and/or fluidly connected. For example, the rim **524** may include an integrated pocket **526** (e.g., a receptacle) within which the sensor device **502** is disposed and attached to the rim **524** (e.g., as described above with respect to the first embodiment of the sensor device **200**, the second embodiment of the sensor device **300**, or the third embodiment of the sensor device **400**, or a different attachment). The rim **524** may also include a pressure sensing port **528** that fluidly connects the sensor device **502** (e.g., the pressure sensor **516** of the sensor device **502**) to a portion of the rim **524** (e.g., a tire cavity defined by a radially outer tire engaging portion). The rim **524** may also include an RFID transmitter **530** (e.g., an NFC

chip) and a health monitoring element **532** (e.g., a composite health monitoring element). The rim **524** and/or the wheel **503** may include more, fewer, and/or different components.

[0195] The pressure sensing port **528** may include an opening through the rim **524** and a connector (e.g., a ported bolt such as the ported bolt **260**, or the ported bolt and a flexible tube) extending through the opening through the rim **524**. The ported bolt, for example, is configured to fluidly connect the sensor device **502** attached to the rim **524**, to the tire cavity, for example. The pressure sensor **516** of the sensor device **502**, for example, is configured to measure a pressure within the tire cavity, for example, via this fluid connection (e.g., including the pressure sensing port **528**).

[0196] The RFID transmitter **530** may be an RFID tag integral with, for example, the rim **524**. For example, the rim **524** may be made of a composite laminate, and the RFID tag **530** may be disposed within (e.g., integral with) the composite laminate of a rim to which the sensor device **502** is attached (e.g., the rim **524**). In one embodiment, the RFID transmitter **530** is an NFC tag. In one embodiment, the wheel assembly **500** includes more than one RFID transmitter **530** embedded within, for example, the rim **524**.

[0197] The RFID tag **530** may be programmed with unique identifying information that may be associated with the rim **524** (e.g., the rim **122**) in which the RFID tag **530** is embedded. When the sensor device **502** is mounted or attached to the rim **524**, for example, a link (e.g., a physical or wireless link) is established between the RFID reader **522** of the sensor device **502** and the RFID tag **530** of the rim **524**. The processor **510** of the sensor device **502** may automatically link relevant information (e.g., measured tire pressure, rim composite health) from the sensor device **502** to the rim **524**. The processor **510** of the sensor device **502** may make this linked information accessible to a user (e.g., the rider or a mechanic) at a computing device (e.g., a smart phone) via the radio **514**. In one embodiment, product registration may be facilitated when the user connects the sensor device to the computing device (e.g., the smart phone or a computer). In one embodiment, the user may choose to receive service and product reminders based on usage information from the sensor device **502** associated with the rim **122**, for example.

[0198] Currently, users (e.g., riders) may keep track of usage of bicycle components manually. The automatic connection of the present embodiments associating the rim **524**, for example, with the sensor device **502**, which may already be associated with the user, allows tracking of relevant information about the rim **524** and provides the ability to make suggestions to the user based on collected data from the sensor device **502** connected to the rim **524**. Examples of suggestions to the user may include, for example, when a minimum threshold tire pressure has been reached or when failure of the composite laminate of the rim **524** has been identified. Automatic association and data tracking of the present embodiments may be used for other components on the bicycle such as, for example, a derailleur or a motor of an ebike.

[0199] The health monitoring element **532** (e.g., the sensing element) may take any number of forms. For example, the health monitoring element **532** may be an insulated conductive wire or a wire mesh. The health monitoring element **532** may be embedded within the composite laminate of the rim **524**, for example, at any number of different locations within the rim **524**. For example, the health

monitoring element **532** may be disposed within the composite laminate forming part of a radially outer tire engaging portion of the rim **524** (e.g., within the first tire retaining portion **202** or the second tire retaining portion **204** of the radially outer tire engaging portion **130** of the rim **122**) or forming part of a radially inner portion of the rim **524** (e.g., the radially inner portion **136** of the rim **122**).

[0200] In one embodiment, the rim **524** includes a plurality of health monitoring elements **532** (e.g., a plurality of sensing elements). The plurality of health monitoring elements **532** may be disposed in any number of different positions within the rim **524**. For example, the plurality of health monitoring elements **532** may include health monitoring elements **532** at different circumferential positions around the rim **524**. Alternatively or additionally, the plurality of health monitoring elements **532** may include health monitoring elements **532** at different positions within a cross-section of the rim **524**. For example, the plurality of health monitoring elements **532** may include one or more health monitoring elements **532** within the radially outer tire engaging portion of the rim **524** and one or more health monitoring elements **532** within the radially inner portion of the rim **524**.

[0201] The health monitoring element **532** may be in communication with the processor **510** of the sensor device **502**, for example, via the resistance measurement interface **523** and the PCB **506** of the sensor device **502**. The processor **510** may identify (e.g., measure) a current and/or a voltage from a signal received at the resistance measurement interface **523**, and determine a resistance and/or a change in resistance or electrical continuity based on the identified current and/or voltage. The processor **510** may compare the determined change in resistance or electrical continuity to a predetermined threshold change, and identify and report structural damage to the health monitoring element **532**, and thus the rim **524**, when, based on the comparison, the determined change in resistance is greater than the predetermined threshold change.

[0202] In one embodiment, in which the health monitoring element **532** is configured as the wire mesh, a resistance of the wire mesh at the time of production may be known (e.g., a predetermined resistance). The processor may compare (e.g., determine a difference between) the known resistance and the determined resistance. Based on the comparison, when the determined difference between the known resistance and the determined resistance is greater than a predetermined threshold difference, the processor **510** may identify and report structural damage to the health monitoring element **532**, and thus the rim **524**. In other words, the processor **510** may identify and report any significant deviation from the known production resistance as structural damage to the rim **524**. In an embodiment in which the rim **524** includes a plurality of health monitoring elements **532**, the processor **510** may monitor the resistance or electrical continuity at each health monitoring element **532** of the plurality of health monitoring elements **532** in parallel.

[0203] In one embodiment, the health monitoring element **532** is in communication with another processor via an antenna of the health monitoring element **532**. The other processor is off of the rim **524**, for example, and is configured to identify and report structural damage to the rim **524** based on changes to the determined resistance of the health monitoring element **532**.

**[0204]** In accordance with various embodiments of the present disclosure, methods described herein may be implemented with software programs executable by a computer system (e.g., of a bicycle controller or computer or a rear derailleur), and/or other components on the bicycle and/or worn by the user. Further, in an exemplary, non-limiting embodiment, implementations may include distributed processing, component/object distributed processing, and parallel processing. Alternatively, virtual computer system processing may be constructed to implement one or more of the methods or functionalities as described herein.

**[0205]** A computer program (also known as a program, software, software application, script, or code) may be written in any form of programming language, including compiled or interpreted languages, and the computer program may be deployed in any form, including as a stand-alone program or as a module, component, subroutine, or other unit suitable for use in a computing environment. A computer program does not necessarily correspond to a file in a file system. A program may be stored in a portion of a file that holds other programs or data (e.g., one or more scripts stored in a markup language document), in a single file dedicated to the program in question, or in multiple coordinated files (e.g., files that store one or more modules, sub programs, or portions of code). A computer program may be deployed to be executed on one computer or on multiple computers that are located at one site or distributed across multiple sites and interconnected by a communication network.

**[0206]** The processes and logic flows described in this specification may be performed by one or more programmable processors executing one or more computer programs to perform functions by operating on input data and generating output. The processes and logic flows may also be performed by, and the apparatus may also be implemented as, special purpose logic circuitry (e.g., an FPGA or an ASIC).

**[0207]** As used in this application, the term ‘circuitry’ or ‘circuit’ refers to all of the following: (a) hardware-only circuit implementations (such as implementations in only analog and/or digital circuitry) and (b) to combinations of circuits and software (and/or firmware), such as (as applicable): (i) to a combination of processor(s) or (ii) to portions of processor(s)/software (including digital signal processor(s)), software, and memory(ies) that work together to cause an apparatus, such as a mobile phone or server, to perform various functions) and (c) to circuits, such as a microprocessor(s) or a portion of a microprocessor(s), that require software or firmware for operation, even if the software or firmware is not physically present.

**[0208]** This definition of ‘circuitry’ applies to all uses of this term in this application, including in any claims. As a further example, as used in this application, the term “circuitry” would also cover an implementation of merely a processor (or multiple processors) or portion of a processor and its (or their) accompanying software and/or firmware, as well as other electronic components. The term “circuitry” would also cover, for example and if applicable to the particular claim element, a baseband integrated circuit or applications processor integrated circuit for a mobile computing device or a similar integrated circuit in server, a cellular network device, or other network device.

**[0209]** Processors suitable for the execution of a computer program include, by way of example, both general and

special purpose microprocessors, and any one or more processors of any kind of digital computer. Generally, a processor receives instructions and data from a read only memory or a random access memory or both. The essential elements of a computer are a processor for performing instructions and one or more memory devices for storing instructions and data. Generally, a computer also includes, or is operatively coupled to receive data from or transfer data to, or both, one or more mass storage devices for storing data (e.g., magnetic, magneto optical disks, or optical disks). However, a computer need not have such devices. Moreover, a computer may be embedded in another device such as, for example, a mobile telephone, a personal digital assistant (“PDA”), a mobile audio player, a Global Positioning System (“GPS”) receiver, a control unit, a rear derailleur, or a front gear changer, to name just a few. Computer readable media suitable for storing computer program instructions and data include all forms of non-volatile memory, media, and memory devices, including by way of example: semiconductor memory devices (e.g., EPROM, EEPROM, and flash memory devices); magnetic disks (e.g., internal hard disks or removable disks); magneto optical disks; and CD-ROM and DVD-ROM disks. The processor and the memory may be supplemented by, or incorporated in, special purpose logic circuitry.

**[0210]** The illustrations of the embodiments described herein are intended to provide a general understanding of the structure of the various embodiments. The illustrations are not intended to serve as a complete description of all of the elements and features of apparatus and systems that utilize the structures or methods described herein. Many other embodiments may be apparent to those of skill in the art upon reviewing the disclosure. Other embodiments may be utilized and derived from the disclosure, such that structural and logical substitutions and changes may be made without departing from the scope of the disclosure. Additionally, the illustrations are merely representational and may not be drawn to scale. Certain proportions within the illustrations may be exaggerated, while other proportions may be minimized. Accordingly, the disclosure and the figures are to be regarded as illustrative rather than restrictive.

**[0211]** While this specification contains many specifics, these should not be construed as limitations on the scope of the invention or of what may be claimed, but rather as descriptions of features specific to particular embodiments of the invention. Certain features that are described in this specification in the context of separate embodiments can also be implemented in combination in a single embodiment. Conversely, various features that are described in the context of a single embodiment can also be implemented in multiple embodiments separately or in any suitable sub-combination. Moreover, although features may be described above as acting in certain combinations and even initially claimed as such, one or more features from a claimed combination can in some cases be excised from the combination, and the claimed combination may be directed to a sub-combination or variation of a sub-combination.

**[0212]** Similarly, while operations and/or acts are depicted in the drawings and described herein in a particular order, this should not be understood as requiring that such operations be performed in the particular order shown or in sequential order, or that all illustrated operations be performed, to achieve desirable results. In certain circumstances, multitasking and parallel processing may be advan-

tageous. Moreover, the separation of various system components in the embodiments described above should not be understood as requiring such separation in all embodiments, and it should be understood that any described program components and systems can generally be integrated together in a single software product or packaged into multiple software products.

**[0213]** One or more embodiments of the disclosure may be referred to herein, individually and/or collectively, by the term “invention” merely for convenience and without intending to voluntarily limit the scope of this application to any particular invention or inventive concept. Moreover, although specific embodiments have been illustrated and described herein, it should be appreciated that any subsequent arrangement designed to achieve the same or similar purpose may be substituted for the specific embodiments shown. This disclosure is intended to cover any and all subsequent adaptations or variations of various embodiments. Combinations of the above embodiments, and other embodiments not specifically described herein, are apparent to those of skill in the art upon reviewing the description.

**[0214]** The Abstract of the Disclosure is provided to comply with 37 C.F.R. § 1.72(b) and is submitted with the understanding that it will not be used to interpret or limit the scope or meaning of the claims. In addition, in the foregoing Detailed Description, various features may be grouped together or described in a single embodiment for the purpose of streamlining the disclosure. This disclosure is not to be interpreted as reflecting an intention that the claimed embodiments require more features than are expressly recited in each claim. Rather, as the following claims reflect, inventive subject matter may be directed to less than all of the features of any of the disclosed embodiments. Thus, the following claims are incorporated into the Detailed Description, with each claim standing on its own as defining separately claimed subject matter.

**[0215]** It is intended that the foregoing detailed description be regarded as illustrative rather than limiting and that it is understood that the following claims including all equivalents are intended to define the scope of the invention. The claims should not be read as limited to the described order or elements unless stated to that effect. Therefore, all embodiments that come within the scope and spirit of the following claims and equivalents thereto are claimed as the invention.

What is claimed is:

**1.** A rim for a bicycle wheel, the rim comprising:

- a radially inner portion disposed along an inner circumference of the rim;
- a first sidewall;
- a second sidewall spaced apart from the first sidewall, wherein the first sidewall and the second sidewall extend radially outward from the radially inner portion;
- a radially outer tire engaging portion disposed along an outer circumference of the rim, the radially outer tire engaging portion extending from the first sidewall and the second sidewall, respectively;
- an opening through the radially inner portion at a first circumferential position along the inner circumference, an air valve of the bicycle wheel being positionable through the opening; and

a receptacle for a sensor device within the radially inner portion at a second circumferential position along the inner circumference, the second circumferential position being different than the first circumferential position.

**2.** The rim of claim **1**, wherein the second circumferential position is opposite the first circumferential position.

**3.** The rim of claim **1**, further comprising the sensor device disposed within the receptacle and attached to the radially inner portion, the radially outer tire engaging portion, or the radially inner portion and the radially outer tire engaging portion.

**4.** The rim of claim **3**, wherein the radially outer tire engaging portion includes a first tire retaining portion extending away from the first sidewall, and a second tire retaining portion extending away from the second sidewall, such that the first tire retaining portion and the second tire retaining portion are spaced apart from each other, and

wherein the sensor device comprises:

- a housing disposed within the receptacle; and
- a pressure sensor supported by the housing and configured to determine a pressure of a fluid within a volume between the first tire retaining portion and the second tire retaining portion of the radially outer tire engaging portion.

**5.** The rim of claim **4**, wherein the sensor device further comprises a power source supported by the housing, wherein the power source is accessible at the inner circumference of the rim.

**6.** The rim of claim **5**, wherein the power source is a battery,

wherein the sensor device further comprises a battery housing removably attached to the housing, the battery housing forming a portion of the inner circumference of the rim, and

wherein the battery is disposable within the battery housing and configured to power the pressure sensor.

**7.** The rim of claim **4**, wherein the pressure sensor is fluidly connected to at least a portion of the radially outer tire engaging portion.

**8.** The rim of claim **7**, further comprising a fastener extending through an opening through the radially outer tire engaging portion,

wherein the fastener is ported, such that a fluid passage extends through the fastener, along a length of the fastener, and

wherein the pressure sensor is fluidly connected to the volume of the radially outer tire engaging portion via the fluid passage extending through the fastener.

**9.** The rim of claim **7**, further comprising:

a cover configured to cover the receptacle and form part of the radially inner portion; and

a toggle bolt configured to connect the cover to the housing of the sensor device, such that the cover is pivotable relative to the housing of the sensor device, wherein the sensor device is positionable within the rim via the receptacle, and

wherein the toggle bolt is further configured to clamp the cover and the sensor device to opposite sides of the radially inner portion, respectively, at the receptacle, such that the sensor device is attached to the radially inner portion.



**10.** The rim of claim **9**, wherein the opening is a first opening,

wherein the rim further comprises:

a bolt that extends through a second opening, the second opening being through the radially outer tire engaging portion, wherein the bolt is attached to the radially outer tire engaging portion at the second opening, and wherein the bolt is ported, such that the bolt has a fluid passage extending through the bolt, along a length of the bolt; and

a flexible hose attached to the housing of the sensor device and the bolt, such that the pressure sensor is fluidly connected to the volume of the radially outer tire engaging portion via the flexible hose and the fluid passage extending through the bolt.

**11.** The rim of claim **4**, wherein the opening is a first opening, and

wherein the rim further comprises:

a flexible container at least partially filled with the fluid, wherein the flexible container is disposed within the volume of the radially outer tire engaging portion; and

a tube that extends through a second opening, the second opening being through the radially outer tire engaging portion, the tube being connected to the flexible container and the housing of the sensor device, such that the pressure sensor is fluidly connected to an interior of the flexible container via the tube.

**12.** The rim of claim **4**, wherein at least part of the rim is made of a composite laminate,

wherein the rim further comprises a sensing element embedded in the composite laminate,

wherein the sensor device further comprises a processor in communication with the sensing element, the processor being configured to:

identify a change in electrical characteristics of the sensing element; and

identify structural characteristics to the rim based on the identified change.

**13.** The rim of claim **12**, wherein the sensing element is a wire mesh with a predetermined resistance, or an insulated electrically conductive wire.

**14.** A sensor device configured to determine a tire pressure of a wheel of a bicycle, the sensor device comprising:

a housing that is disposable within a receptacle within a radially inner portion of a rim of the wheel of the bicycle, such that a portion of the housing forms part of the radially inner portion of the rim;

a pressure sensor supported by the housing, wherein the housing is connectable to a radially outer tire engaging portion of the rim, such that the pressure sensor is fluidly connected to a tire cavity of the wheel and the pressure sensor is configured to determine a pressure within the tire cavity;

a battery configured to power the pressure sensor; and  
a battery housing configured to support the battery, the battery being removably attached to the housing at the portion of the housing, such that the battery is accessible at the radially inner portion of the rim.

**15.** The sensor device of claim **14**, further comprising:  
a radio-frequency identification (RFID) reader supported by the housing; and

a processor supported by the housing, the processor being electrically connected to the pressure sensor, the battery, and the RFID reader,

wherein the RFID reader is configured to receive a signal from an RFID transponder disposed on or embedded within the rim when the housing of the sensor device is disposed within the receptacle, and

wherein the processor is configured to:

identify the rim based on the received signal; and  
associate the determined pressure with the rim.

**16.** A bicycle wheel comprising:

a rim comprising:

a radially inner portion disposed along an inner circumference of the rim;

a first sidewall;

a second sidewall spaced apart from the first sidewall, wherein the first sidewall and the second sidewall extend radially outward from the radially inner portion; and

a radially outer tire engaging portion disposed along an outer circumference of the rim, the radially outer tire engaging portion including a first tire retaining portion extending away from the first sidewall, and a second tire retaining portion extending away from the second sidewall, such that the first tire retaining portion and the second tire retaining portion are spaced apart from each other; and

a receptacle within the radially inner portion;

a sensor device disposed within the receptacle and attached to the radially inner portion, the radially outer tire engaging portion, or the radially inner portion and the radially outer tire engaging portion, the sensor device comprising:

a housing; and

a pressure sensor supported by the housing; and

a flexible container at least partially filled with a fluid, wherein the flexible container is disposed within a volume between the first tire retaining portion and the second tire retaining portion of the radially outer tire engaging portion,

wherein the pressure sensor is fluidly connected to an interior of the flexible container, such that the pressure sensor is configured to determine a pressure of the fluid within the flexible container.

**17.** The bicycle wheel of claim **16**, wherein the opening is a first opening,

wherein the rim further comprises a tube that extends through a second opening, the second opening being through the radially outer tire engaging portion, and

wherein the tube is connected to the flexible container and the housing of the sensor device, such that the pressure sensor is fluidly connected to the interior of the flexible container via the tube.

**18.** The bicycle wheel of claim **16**, wherein the fluid is a first fluid, and

wherein the determined pressure of the first fluid corresponds to a pressure of a second fluid surrounding the flexible container.

**19.** The bicycle wheel of claim **18**, wherein the first fluid is an incompressible fluid.

**20.** The bicycle wheel of claim **18**, wherein the pressure of the second fluid surrounding the flexible container is a tire pressure when a tire is attached to the rim.